

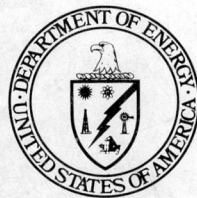

Atmospheric Radiation Measurement Program Plan

February 1990



U.S. Department of Energy
Office of Energy Research
Office of Health and Environmental Research
Atmospheric and Climate Research Division

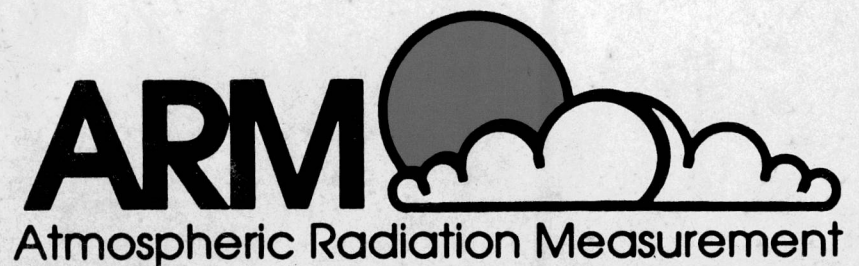

This report has been reproduced directly from the best available copy.

Available from the National Technical Information Service, U. S. Department of Commerce, Springfield, Virginia 22161.

Price: Printed Copy A07
Microfiche A01

Codes are used for pricing all publications. The code is determined by the number of pages in the publication. Information pertaining to the pricing codes can be found in the current issues of the following publications, which are generally available in most libraries: *Energy Research Abstracts, (ERA)*; *Government Reports Announcements and Index (GRA and I)*; *Scientific and Technical Abstract Reports (STAR)*; and publication, NTIS-PR-360 available from (NTIS) at the above address.



Atmospheric Radiation Measurement Program Plan

February 1990



U.S. Department of Energy
Office of Energy Research
Office of Health and Environmental Research
Atmospheric and Climate Research Division
Washington, D.C. 20545

ARM 
Atmospheric Radiation Measurement

ANTHONY
RICHARD
MAGUIRE
MAGUIRE

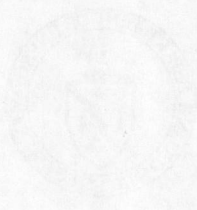

U.S. DEPARTMENT OF JUSTICE
Office of the Inspector General
Washington, D.C. 20535



ANTHONY RICHARD MAGUIRE

Foreword

In 1978 the Department of Energy initiated the Carbon Dioxide Research Program to address climate change from the increasing concentration of carbon dioxide in the atmosphere. Over the years the Program has studied the many facets of the issue, from the carbon cycle, the climate diagnostics, the vegetative effects, to the societal impacts. The Program is presently the Department's principal entry in the U.S. Global Change Research Program coordinated by the Committee on Earth Sciences (CES) of the Office of Science and Technology Policy (OSTP).

The recent heightened concern about global warming from an enhanced greenhouse effect has prompted the Department to accelerate the research to improve predictions of climate change. The emphasis is on the timing and magnitude of climate change as well as on the

regional characteristics of this change. The Atmospheric Radiation Measurement (ARM) Program was developed to supply an improved predictive capability, particularly as it relates to the cloud-climate feedback.

Scientists from the DOE National Laboratory community contributed to the preparation of the ARM Program Plan with input from members of the academic community, the private sector, and from scientists of other CES agencies. The Plan was subjected to an extensive peer review and the many helpful comments we have received have been incorporated into this document. We believe that ARM will serve the CES objectives in Global Change research and support the DOE mission of formulating a National Energy Strategy that takes into account the potential for global climate change.

Dr. Ari Patrinos, Acting Director
Atmospheric and Climate Research Division

Foreword

The primary purpose of this book is to provide a comprehensive overview of the current state of research in the field of [unintelligible]. The book is organized into several chapters, each focusing on a different aspect of the field. The first chapter, [unintelligible], provides a historical context for the field and discusses the key figures who have shaped its development. The second chapter, [unintelligible], discusses the theoretical foundations of the field and the various models that have been proposed. The third chapter, [unintelligible], focuses on the empirical research that has been conducted in the field and discusses the methods that have been used. The fourth chapter, [unintelligible], discusses the practical applications of the research and the ways in which it has been used to solve real-world problems. The fifth chapter, [unintelligible], discusses the future of the field and the challenges that lie ahead. The book is intended for a wide range of readers, including students, researchers, and practitioners in the field. It is hoped that this book will provide a valuable resource for anyone interested in the field of [unintelligible].

Author's Name
 Department Name
 Institution Name

Contents

| | |
|--|-----|
| Foreword | iii |
| Objective | 1 |
| Introduction | 3 |
| Background | 5 |
| Overview of General-Circulation and Radiative Transport Modeling | 5 |
| General Circulation Modeling | 5 |
| Radiative Transfer Modules | 8 |
| Model Intercomparison Activities | 10 |
| A Regional GCM Intercomparison | 10 |
| Intercomparison of Surface Energy Budgets | 11 |
| A GCM Intercomparison and the Earth Radiation Budget Experiment | 12 |
| The Intercomparison of Radiation Codes Used in Climate Models | 14 |
| Program Requirements | 19 |
| The Goals of the ARM Program | 19 |
| The Importance of the Radiation Field in Modeling Climate | 19 |
| The "Figure of Merit" for the ARM Experiment | 20 |
| The Resolution and Parameterization Problem | 20 |
| The Basic Experimental Approach to ARM | 23 |
| Test Radiative Models | 23 |
| Expand to GCM and Satellite Scale | 23 |
| GCM Cloud Parameterization | 23 |
| Constraining the Radiation Models | 24 |
| Radiation Measurements | 24 |
| Characterizing the Atmosphere | 26 |
| Basic Meteorological Measurements | 26 |
| Atmospheric Composition | 27 |
| Geometrical Structure of the Atmosphere | 27 |
| Surface Properties | 27 |

| | |
|---|----|
| Analysis Requirements | 27 |
| Direct Comparison of Observations with Model Calculations | 28 |
| Obtaining Parameterizations from ARM Measurements | 29 |
| Parameterization, Testing and Development | 29 |
| Measurement Accuracy Requirements | 32 |
| Site Selection Issues | 34 |
| Experimental Design | 35 |
| The Basic Elements of the Measurement Program | 35 |
| Base Sites: The Measurement of the Column | 36 |
| In Situ Sampling Program | 38 |
| Extended Observing Stations: Measuring the GCM Grid Cell | 39 |
| Mobile ARM Observing System | 40 |
| Proposed Experimental Technologies: The Technological Response to the Requirements | 42 |
| The Base Site Instrumentation | 43 |
| Extended Observing Station Instrumentation | 46 |
| Aircraft-Borne Operations and Campaign Measurements | 47 |
| Calibration | 48 |
| Site Selection | 51 |
| Site Selection Considerations | 51 |
| Rationale for Multiple ARM Sites | 53 |
| Potential ARM Sites and Priorities | 54 |
| Proposed Data Management Strategies | 56 |
| Data Flow Overview | 57 |
| System Overview | 59 |
| Relationship to Other Data Systems and Centers | 62 |
| Research Needs: Remote Sensing and Laboratory Spectroscopy | 63 |
| Remote Sensing and Radiometric Instrumentative | 63 |
| Laboratory Spectroscopy Program | 63 |

| | |
|--|-----|
| Management Plan | 65 |
| Management Structure | 65 |
| Management of the Clouds and Radiation Testbed | 66 |
| Implementation of the ARM Program | 68 |
| Design of the Project Infrastructure | 68 |
| Formation of the Science Team | 69 |
| Instrument Deployment and the Instrument Development Program | 70 |
| Formation of the Data Management Team | 71 |
| Development of an Operations Strategy | 71 |
| Relationship to Other Programs | 72 |
| Complementary Scientific Programs | 73 |
| Long-Term Field and Monitoring Program | 75 |
| Instrument Development Programs | 76 |
| International Programs | 77 |
| Schedule and the Deployment of ARM | 79 |
| Budget Projections | 80 |
| Appendix A - Brief History of the Department of Energy Carbon Dioxide Research Program | 83 |
| Appendix B - Current Measurement Technologies | 85 |
| References | 105 |
| Acronyms and Abbreviations | 113 |

Figures and Tables

Figures

| | | |
|----|--|----|
| 1 | Mean annual radiation and heat balance of the atmosphere for climate considerations. | 6 |
| 2 | A typical GCM global grid scale. | 8 |
| 3 | The GCM grid of Figure 2 superimposed on a storm system in the Southeast U.S. | 8 |
| 4 | Spectral distribution curves related to the sun. | 9 |
| 5 | Cess intercomparison findings: model sensitivity vs. cloud radiative forcing. | 13 |
| 6 | The difference between FASCOD2-calculated and HIS-measured radiance spectra found by Dr. William Smith, University of Wisconsin. | 16 |
| 7 | The ARM experimental approach as applied to the study of the radiation field. | 24 |
| 8 | Linkages of the cloud parameterization, radiation modeling and observation programs. | 30 |
| 9 | Spectral distribution of possible errors in calculated spectral flux (or intensity) due to systematic (a) and random (b) errors in the tropospheric water vapor distribution. | 33 |
| 10 | As in Figure 9 but for the temperature distribution. | 33 |
| 11 | Clouds and Radiation Testbed. | 36 |
| 12 | Conceptual design for the central facility of the ARM experimental network. | 37 |
| 13 | An idealized representation of the generation and metamorphosis of cloud and precipitation particles. | 38 |
| 14 | The NOAA mobile lidar unit. | 41 |
| 15 | An artist's conception of the radiometric calibration facility at the Solar Energy Research Institute. | 49 |
| 16 | The calibration of radiometric instruments often involves the intercomparison of different kinds of sensors using the sun as the calibration source. | 50 |
| 17 | Conceptual design of ARM data flow. | 57 |
| 18 | Components of the ARM data management system. | 60 |
| 19 | DOE oversight of ARM showing the Interagency Steering Group and the three programmatic elements of ARM. | 66 |
| 20 | Internal Management of ARM. | 67 |
| 21 | Atmospheric Radiation Measurement Program schedule and budget for four (1-4) fixed sites and one mobile (m) site. | 81 |
| 22 | The Rotating Shadowband Radiometer. | 87 |

| | | |
|----|--|----|
| 23 | The Rotating Shadowband Spectrometer. | 88 |
| 24 | A large-scale RASS antenna array. | 96 |

Tables

| | | |
|---|--|-----|
| 1 | The spectrophotometric recommendations for ARM. | 44 |
| 2 | Aircraft-based measurement systems. | 48 |
| 3 | ARM budget in millions. | 80 |
| 4 | Measurable meteorological parameters from remote sensing systems. | 91 |
| 5 | NOAA Wave Propagation Laboratory remote sensing facilities. | 98 |
| 6 | Summary of key cloud-microphysics measurements. | 100 |

Objective

In order to understand energy's role in anthropogenic global climate change, significant reliance is being placed on General Circulation Models (GCMs). A major goal of the Department is to foster the development of GCMs capable of predicting the timing and magnitude of greenhouse gas-induced global warming and the regional effects of such warming. DOE research has revealed that cloud radiative feedback is the single most important effect determining the magnitude of possible climate responses to human activity. However, cloud radiative forcing and feedbacks are not understood at the levels needed for reliable climate prediction.

The Atmospheric Radiation Measurement (ARM) Program will contribute to the DOE goal by improving the treatment of cloud radiative forcing and feedbacks in GCMs. Two issues will be addressed: the radiation budget and its spectral dependence and the radiative and other properties of clouds. Understanding cloud properties

and how to predict them is critical because cloud properties may very well change as climate changes.

The experimental objective of the ARM Program is to characterize empirically the radiative processes in the Earth's atmosphere with improved resolution and accuracy. A key to this characterization is the effective treatment of cloud formation and cloud properties in GCMs. Through this characterization of radiative properties, it will be possible to understand both the forcing and feedback effects. GCM modelers will then be able to better identify the best approaches to improved parameterizations of radiative transfer effects. This is expected to greatly improve the accuracy of long-term, GCM predictions and the efficacy of those predictions at the important regional scale, as the research community and DOE attempt to understand the effects of greenhouse gas emissions on the Earth's climate.

The first part of the report deals with the general situation of the country and the progress of the work during the year. It is followed by a detailed account of the various projects and the results achieved. The report concludes with a summary of the work done and the prospects for the future.

Introduction

The mission of the Department of Energy (DOE) is to provide an environmentally safe, economically sound, and politically secure energy future for the nation. The Department is now engaged in a major effort to define a National Energy Strategy that will accomplish this mission. The possibility of global climate change resulting from energy production is an issue central to this strategy.

During the past decade, DOE has carried forward a focused research program to examine the greenhouse effect. This program has addressed the full range of issues related to carbon dioxide (CO₂) and other important greenhouse gases. The mission of the program has been to estimate the future levels and rate of increase in atmospheric CO₂ and greenhouse gases and to determine potential effects on climate and biota. This information is required to support scientifically based energy policy options which can prevent, mitigate, or adapt to potential global warming. The thrust of the past decade of DOE research has been to:

1. Elucidate the processes that control the global carbon cycle and provide predictions of future atmospheric CO₂ change
2. Develop data and models of the processes by which changes in the Earth's radiative balance may change climate at global and regional scales and predict rates of potential climate change
3. Develop the data and models required to define and predict the combined effect of climate change and the direct effect of CO₂ on plants, crops, and ecosystems.

The research findings of this program are presented in a series of State-of-the-Art reports (DOE 1985), individual technical reports, and the scientific literature.^(a)

Scientific and public interest in the greenhouse effect has increased dramatically over the last two years. Simultaneous arguments are being made to initiate both immediate energy policy action and careful research to address this important scientific question before limiting our energy options. Defining an appropriate response to the concern of global climate change is a major challenge given the present uncertainties associated with predictions of the magnitude and timing of such a change.

In response to this challenge, the Office of Energy Research has developed an initiative called "Atmospheric Radiation Measurement" (ARM), which is designed to improve the treatment of cloud radiative forcing in General Circulation Models (GCMs). This initiative was selected after a careful review of the most critical gaps in the knowledge needed to improve the predictive accuracy of climate models. Together with the complementary scientific efforts of other federal agencies, the DOE program is intended to provide more accurate predictions of climate effects.

The ARM Program tackles the key problems of developing both the scientific data and the analytical approach needed to link quantitatively changes in atmospheric composition to changes in radiative forcing. The program emphasizes cloud radiative forcing, which has been identified by the Committee on Earth Sciences as one of the most critical elements for understanding induced global climate change.

(a) A listing of the publications of the DOE research program is updated twice a year. The listing is available from the Department of Energy, Atmospheric and Climate Research Division, ER-76, Washington, D.C. 20545.

The challenge of the program is to characterize the physical and dynamical structure of the column with sufficient accuracy to significantly improve the modeling of critical phenomena. Experimentally, this will entail measuring the radiative fluxes, temperature, atmospheric composition, and wind velocity at four to six highly instrumented sites. Data from ground-based sensors, arrayed around each base site, will relate the information collected in the column to the requirements for modeling an area the size of a GCM grid cell.

This approach will allow quick implementation, flexible measurement techniques, and the economical use of resources. It will also provide the opportunity to exploit new instrumental and scientific advances as they occur. It is important to begin this effort immediately. Although there will be important intermediate results of the program, we estimate that ten years of study will be necessary to support the continued development of models which address problems of parameterization in the climate models.

The scientific roots for ARM are found in the Climate Diagnostics element of the DOE Carbon Dioxide Research Program. The objectives of the Climate Diagnostics element are to:

1. Diagnose the causes of disagreements among model results and between model results and climate observations
2. Obtain and analyze the atmospheric observations required to validate climate models and detect climate change

3. Improve the ability of models to estimate the effects of changes in radiative forcing on climate and to assign causal links to these effects.

The ARM Initiative has been motivated primarily by results from the first objective and may be considered an extension of the third objective. The technology necessary to achieve the goals of ARM is available now. This document describes the critical elements of the DOE plan to deploy the ARM experiment and to initiate observations at the first site by April 1992.

The document is organized as follows. The Background Section provides the technical background in previous modeling and measurement intercomparisons that led to the ARM Initiative. The Program Requirements Section highlights the scientific needs associated with understanding and predicting global climate change that emerged from the intercomparisons. The Experimental Design Section describes the practical design for the ARM experiment, which responds to the key features of the needs identified in the Requirements Section.

The management strategy and implementation for ARM are discussed in the Management Plan Section as is the interaction with several key national and international climate research programs which will be continuing and beginning during the proposed ARM timeline. The ARM Program demands, and will work for, a strong synergistic relationship with these programs in order to achieve the program goals.

Background

Background

The major driving forces for the research program described in this plan can be summarized by three statements:

- Extensive application of advanced General Circulation Models (GCMs) is the only way to effectively address many critical national questions regarding global climate change.
- Uncertainty associated with current GCMs renders them inadequate for definitive resolution of many of these critical questions.
- The representation of clouds, including their effects on the radiant-energy transfer portions of existing codes, constitute a major source of model uncertainty.

This section provides the general background, derived from previous modeling and measurement investigations, to substantiate these three statements. A brief summary of GCMs and radiative transport models is presented first. It defines the more important general terms and concepts used in the subsequent discussion. Following this preliminary material is a more detailed discussion of previous model evaluations and other studies. These studies led to the plan for research under this program.

Overview of General-Circulation and Radiative-Transport Modeling

This introductory section is intended to define terminology for the reader not totally familiar with GCM and radiation-balance calculations. The more informed reader may wish to skip this material and proceed directly to the Model Intercomparison Activities section.

General Circulation Modeling

The mathematical descriptions of the climate system widely known as GCMs are computer programs which solve, approximately, the set of coupled differential equations representing conservation of atmospheric momentum, energy, and mass. A basic form of the momentum-conservation equation is:^(a)

| | |
|---|--|
| $\frac{\partial \rho \mathbf{v}_{\text{air}}}{\partial t} =$ | Time rate of change of momentum in a small volume element of atmosphere, per unit volume |
| $- \nabla \cdot \rho \mathbf{v}_{\text{air}} \mathbf{v}_{\text{air}}$ | rate of loss of momentum by transport through walls of volume element, per unit volume |
| $- \nabla p$ | pressure forces acting on element, per unit volume |
| $- \mathbf{F}_v$ | viscous forces acting on element, per unit volume |
| $+ \rho \mathbf{g}$ | gravitational forces acting on element, per unit volume |

(Equation 1)

where ρ is the local air density, \mathbf{v}_{air} is its velocity vector, and \mathbf{g} represents the acceleration of gravity.

(a) This and the following balance equations are expressed in condensed, vector form for brevity. Expanded forms and further description can be found in textbooks on this subject (e.g., Washington and Parkinson 1986).

A corresponding form for energy conservation is:

$$\frac{\partial}{\partial t} (\rho C_v T) =$$

Time rate of change of sensible energy in a unit volume of atmosphere

$$- \nabla \cdot (\rho C_v T \mathbf{v}_{air})$$

rate of loss of sensible energy by flow through walls of volume element

$$- p (\nabla \cdot \mathbf{v}_{air})$$

rate of work done by system by expansion

$$+ \Gamma$$

rate of sensible heat gained via latent heating effects

$$+ \tilde{R}$$

rate of sensible heat gained by radiant heating effects

(Equation 2)

where C_v represents the specific heat of air at constant volume. Principal outputs of solutions to the momentum and energy equations, are time varying, three-dimensional fields of the wind velocity vector (\mathbf{v}) and atmospheric temperature (T). The energy balance contains terms for the transfer of sensible and latent energy and electromagnetic radiation. Figure 1 shows some of the important energy flows that GCMs must describe.

The radiation and energy balance of the Earth's atmosphere involves a complicated set of inter-related processes. The experimental portions of the ARM Program will attempt to measure many of the energy fluxes shown in the figure. The figure demonstrates the importance of integrating the ARM program with satellite observations.

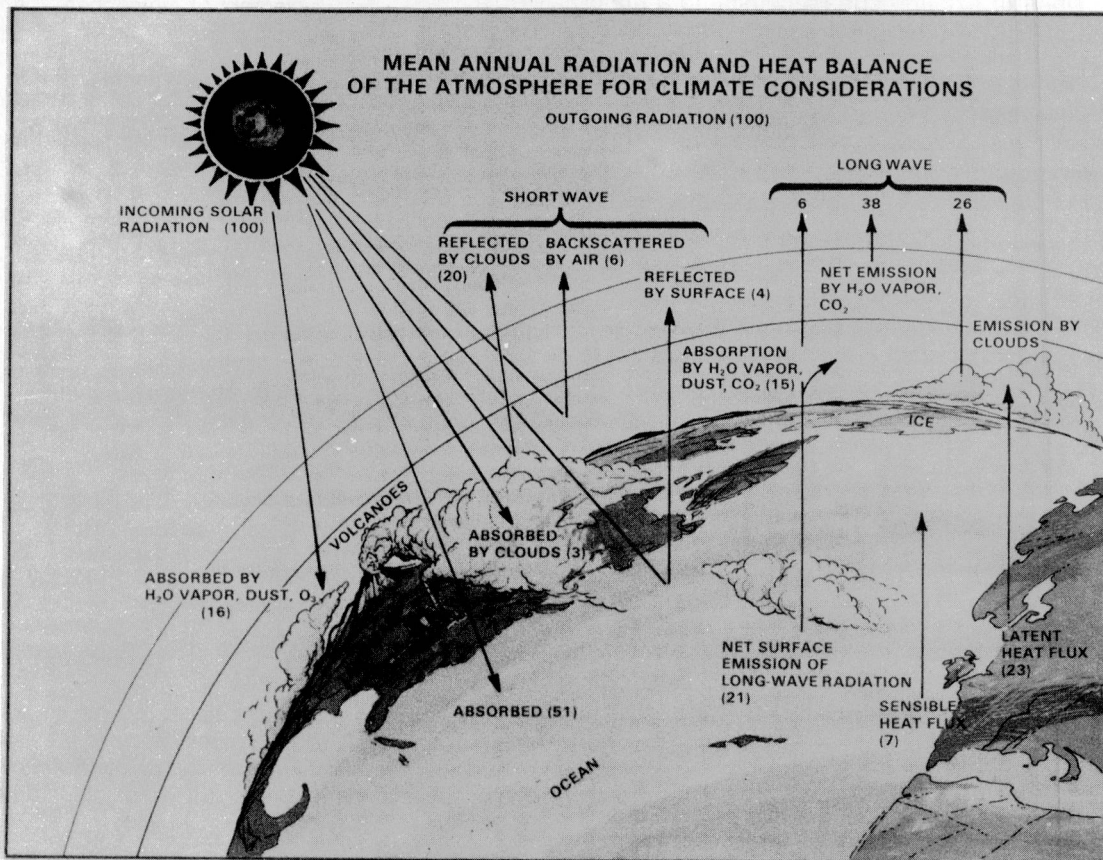

Figure 1. Mean annual radiation and heat balance of the atmosphere for climate considerations.

The combination of ARM, with its ability to examine lower tropospheric processes in detail, with the satellite's global coverage of the outgoing radiation will make a powerful measurement system.

Usually, GCMs contain more than one conservation equation for mass. The mass-continuity equation for air, which is an essential requirement for any GCM, is:

$$\frac{\partial \rho}{\partial t} = \text{Time rate of change of air density in a small volume element of atmosphere}$$

$$- \nabla \cdot (\rho \mathbf{v}_{\text{air}}) \text{ rate of loss of air by transport through walls of volume element.}$$

(Equation 3)

This is accompanied by the continuity equation for water:

$$\frac{\partial c_{\text{wv}}}{\partial t} = \text{Time rate of change of concentration of water vapor in a small volume element of atmosphere}$$

$$- \nabla \cdot (c_{\text{wv}} \mathbf{v}_{\text{air}}) \text{ rate of loss of water vapor by transport through walls of volume element}$$

$$+ W_{\text{wv}}^* \text{ rate of gain of water vapor by phase transformation.}$$

(Equation 4)

Equation 4 may be subdivided into separate equations for different phases of water (vapor, clouds, ice, . . .). However, computational constraints usually limit the extent of this subdivision. Solutions to material balance equations 3 and 4 result in time varying three-dimensional fields of concentrations (or densities) of the material conserved by the equations.

GCMs approximate solutions to the above differential equations using a variety of numerical-integration techniques.^(a) Common to all, however, is the practice of dividing the computational domain (the global atmosphere, in the case of a global GCM) into a three-dimensional grid-mesh similar to that shown in Figure 2. The

solution space is then tied to points on this grid. Most of today's GCMs operate with about 10 layers in the vertical, and have a horizontal grid spacing of roughly 500 km. Both the potential accuracy of the code's numerical approximations and the required computer time increase with grid resolution. Halving the grid spacing in the x, y, and z directions will generally result in an 8-fold increase in required computer storage and a 16-fold increase in computer time.^(b) Thus, an important trade-off exists between accuracy and computational economy. While these computational issues are a significant concern, a second manifestation of coarse grid spacing is far more important. Many meteorological phenomena that are primary determinants and manifestations of global weather occur on small scales. These scales are small enough to escape resolution by the model's grid-mesh.

Figure 3 demonstrates this effect. The figure shows a typical horizontal GCM grid superimposed on a storm system crossing the North American continent. The important processes of cloud formation, precipitation, albedo change,

(a) Most of today's GCMs apply standard finite differencing for integrating in the vertical dimension, and use so-called "spectral" or "pseudospectral" techniques for integration in the horizontal. The latter technique involves Fourier-transformation of the dependent variables into a frequency domain, truncation of all contributions above a specified wave number, algebraic manipulation, and then inversion back to the original solution domain. The reader should not confuse the spectral terms (e.g., wave length, wave number, frequency, . . .) associated with this numerical technique with similar terms pertaining to electromagnetic phenomena or atmospheric motions.

(b) By a simple examination of numerical-analysis techniques one can demonstrate that halving the grid spacing in any direction will double the number of grid points and essentially double the amount of memory and the number of computations required for a solution. Thus, halving for three dimensions results in a $2^3 = 8$ -fold increase. For reasons of computational stability, however, one normally is required to reduce the computational time-step proportional to any reduction in the spatial grid; thus, a total computational time increase of $2^4 = 16$ -fold results.

The combination of ARM with the satellites global coverage of the outgoing radiation will make a powerful measurement system.

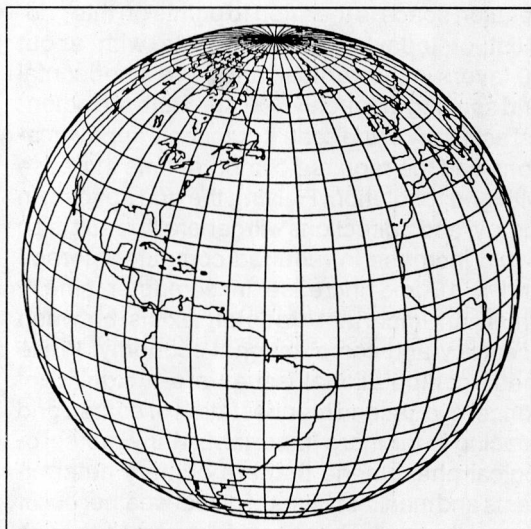

Figure 2. A typical GCM global grid scale.

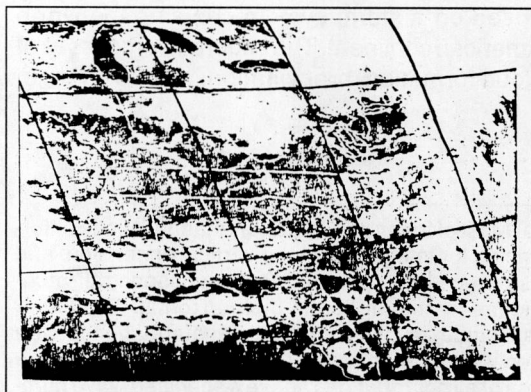

Figure 3. The GCM grid of Figure 2 superimposed on a storm system in the Southeast U.S.

radiant energy transfer, and vertical and horizontal transport are taking place at small scales within the storm system. At best, these phenomena will be highly blurred by the coarse-grid model. At worst, these processes may totally escape detection or processing by the code. The effects of these unresolved phenomena are usually included in GCMs through the process of parameterization. An important issue is assuring that these parameterizations adequately

represent current climate and can evolve with the climate in an appropriate physical manner.

Radiative Transfer Modules

GCMs are complex entities. It is usually convenient to visualize these codes as computational frameworks. Within the framework are interacting "modules" that compute individual features of the total system. For example, a given code may have a module to compute evapotranspiration, another to describe cloud formation, and yet another to compute the radiative component of the energy balance. A key issue addressed by the ARM Program is that current radiative transport modules are particularly susceptible to inaccuracy.

Figure 1 provides a schematic of some of the more common elements of a radiative transport module. Electromagnetic energy from the sun encounters the Earth's atmosphere. This energy is partly absorbed by the atmosphere, partly reflected back into space, and partly transmitted to the Earth's surface. At the surface partial absorption and partial reflection again occur. Radiation absorbed either by atmospheric constituents or by the Earth heats both. This energy is eventually re-emitted at longer, infrared wavelengths to participate in further atmospheric interactions and, ultimately, escapes to outer space.

About 99% of the solar radiation is at wavelengths less than 3 micrometers, whereas about 99% of the thermally emitted radiation is at wavelengths greater than 3 micrometers. The terms "shortwave" and "longwave" are often used to denote the solar and thermally emitted radiation.

Three major features complicate the problem of modeling the Earth's radiation balance. First, radiant energy transport is a compound process, involving multiple stages of absorption, reflection, and re-emission. These processes depend in a complex way on absorption characteristics of individual atmospheric gases and particles.

Among the most important of these are the microphysical and morphological features of clouds. Further, various molecules and particles in the atmosphere, as well as the surface of the Earth itself, have a rich infrared emission spectrum. The development of an adequate model framework for reliable computation of these features, especially in a coarse GCM grid structure, is a particularly challenging goal.

Secondly, the absorption, emission, and reflection processes associated with the Earth's atmosphere and surface are strongly wavelength dependent. Specific greenhouse gases, clouds, and atmospheric aerosols attenuate the solar spectrum in very characteristic spectral patterns. The distribution of energy with wavelength, observed in the shape of the electromagnetic spectrum, affects and is affected by these radiative transfer processes. Therefore, highly resolved spectral calculations must be applied in order to obtain a detailed characterization of radiative transfer. Such models are computationally demanding and require fine tuning from empirical data for accuracy.

Finally, and as can be observed from the energy-conservation equation 2, the radiant component of the total energy balance is strongly coupled with sensible and latent heat fluxes. While it is convenient to isolate radiant transport for discussion purposes, this element ultimately must be linked with other components for practical calculations. Moreover, observational analyses of atmospheric radiant transport must take into account the interactions among components in order to provide useful results.

The second complicating feature described above involves the shape of the electromagnetic spectrum. The solar spectrum approaching the Earth's outer atmosphere is a reasonably smoothly varying function of wavelength, punctuated with relatively broad absorption lines. These lines correspond to quantum transitions of excited atoms in the outer layers of the sun. Differential absorption and scattering distort the spectrum markedly as it moves through the atmosphere toward the Earth's surface. Figure 4 demonstrates this effect through a comparison of the

extraterrestrial solar spectrum and the transmitted spectrum at the Earth's surface.

The techniques used to calculate the transfer of electromagnetic radiation in the atmosphere may generally be classified according to the manner used to perform the wavelength integration across the short-and-longwave regions. The first of these, known generally as "broad-band" computation, divides the short-or-longwave spectrum into a few intervals. The spectrally-integrated processes for each broad interval are typically determined with the use of adjustable parameters chosen from more detailed calculations. A second approach, known as the "narrow-band" technique, attempts to improve this approximation by more finely dividing the spectrum so as to better approximate the spectral properties of atmospheric absorption bands. The widths of the spectral intervals in the narrow-band technique are about two orders of magnitude greater than the widths of the individual absorption lines.

The most precise method is known as the "line-by-line" technique. Computations with this technique deal directly with each line of the terrestrial spectrum. However, since these calculations are extremely computer-time consuming, they

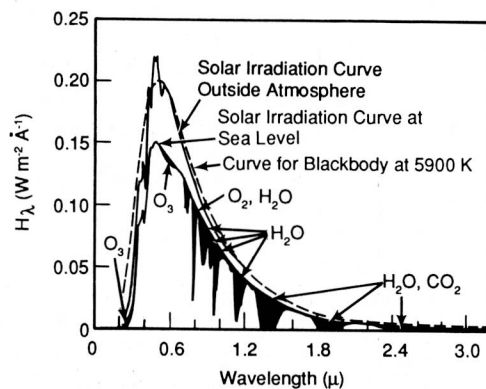

Figure 4. Spectral distribution curves related to the sun. The shaded areas indicate absorption, at sea level, due to the atmospheric constituents shown. (From Gast et al.; McGraw-Hill 1965.)

are not practical for use in climate models. Although line-by-line techniques result in the most highly resolved treatment of atmospheric radiative transport, uncertainties remain concerning the shapes and strengths of the individual atmospheric absorption lines.

Model Intercomparison Activities

The direct impetus for the ARM Initiative was derived from the integrated results of four major GCM intercomparisons. The four intercomparison experiments include comparisons of models with historical data, intercomparison of models' surface energy budgets, a comparison of models with data from the Earth Radiation Budget Experiment (ERBE), and a detailed study of various GCM radiative transfer codes.

Although each of these programs has had a somewhat different focus, they all have come to a similar conclusion. That is: although general agreement among GCMs is improving with respect to basic climatological results on the global scale, this agreement is not necessarily an indicator of significant progress toward the goal of creating GCMs capable of prediction on the sub-continental, regional, scale. While observed and predicted atmospheric variables averaged around a latitude circle (i.e., zonally-averaged) seem to be in general agreement, regionally-averaged quantities are in much poorer agreement. For predictive purposes, it is regional level results which are most useful and necessary.

Each of the intercomparison studies isolates a specific cause for the disagreement in the models. The parameterizations of critical physical processes vary from model to model. Among those models for which results are beginning to converge, the improved agreement is driven by internal evolution of the models, rather than by any conformity to actual data. Major model uncertainties about the treatment of clouds, as well as errors in clear-sky radiative codes, dwarf the radiative forcing effects due to potential increases in the concentration of atmospheric trace gases (i.e., CO₂, CH₄, N₂O, etc.).

These four intercomparisons, viewed as a whole, suggest a definite direction for future GCM research. The Grotch (1988) intercomparison of GCMs with historical regional climatology demonstrates that future GCM research needs to improve regional predictions. The failure of current GCMs to converge on accurate regional predictions is not surprising. Two of the other studies point out that the surface energy budget and its relationship to the hydrologic cycle (Wang et al. 1986) and radiative transfer (Luther et al. 1988) are still not being adequately treated in GCMs. Both of these studies show discrepancies among the models several times larger than the projected anthropogenic radiative forcing. In short the models disagree in the basic energy balance at climatologically significant levels.

Most importantly, Cess et al. (1989) show that there are significant disagreements among models in their estimates of the radiative effects of clouds under very closely controlled experimental conditions. As pointed out by Gates (1987), it is unreasonable to expect that the next generation of models will produce more accurate results unless we properly represent the basic energy budgets and radiative forcing.

A Regional GCM Intercomparison

Grotch (1988) compared the results of four different GCMs that had been used to project the climatic consequences of a doubling of atmospheric CO₂. The intercomparison involved models developed by groups at the National Center for Atmospheric Research (NCAR) (Washington and Meehl 1984), NOAA's Geophysical Fluid Dynamics Laboratory (GFDL) (Manabe and Wetherald 1987), NASA's Goddard Institute for Space Studies (GISS) (Hansen et al. 1984) and a fourth model from Oregon State University (OSU; Schlesinger 1986).

The study included two model variables: surface air temperature and precipitation. The analysis examined the variables for both seasonally and annually averaged periods, for current climatic

The failure of current GCMs to converge on accurate regional predictions is not surprising.

conditions and for predicted equilibrium conditions after a doubling of current CO₂ concentration. For the current climate, the model results for these two variables were compared with each other and with several data sets representing observed climate conditions over recent 15- to 30-year periods. The grid resolution of the different models being examined varied from 4° latitude by 5° longitude to 8° latitude by 10° longitude. The data were available with similar resolution. Thus, data points on the model or observation grid represented regions of about 400 by 400 km, roughly the size of Colorado.

Previous comparisons of GCMs emphasized their global-scale nature (Schlesinger and Mitchell 1985). The Grotch intercomparison evaluated models and data over a range of scales: global, hemispheric, zonal, continental, and regional. The study attempted to determine how well the predictions from different GCMs agreed with each other and with historical climatology over these different scales. Grotch and colleagues drew several major conclusions based on an analysis of their intercomparison data.

Principal Findings

1. Although the results of the GCMs often appeared to agree well with each other and with historical surface air temperature data over large global and continental scales, significant differences were found at subcontinental scales (regions containing 5 to 20 grid-points). GCM prediction is not yet sufficiently sophisticated to be used for quantitative prediction at a multistate regional level, let alone for a particular state, county or city.
2. Two of the GCMs suggest that the seasonal variation of surface air temperature is poorly represented. The seasonal surface air temperature simulated by the GISS model for summer (June-July-August) and the OSU model in winter (December-January-February) differ significantly from historical data.
3. Spatially averaged values can be misleading indicators of good agreement and can suggest erroneous conclusions. Significant differences can result at scales well below the level at which the average has been estimated. Two models can have the same average value for a variable over a region and yet exhibit very different distributions of that variable within the region.
4. One model may be in better agreement with historical data than another for a particular variable over a given region in one season and show poorer agreement when compared with another model over the same region in a different season. None of the models compared were adequate for use in detailed seasonal perturbation studies.

Intercomparison of Surface Energy Budgets

Wei-Chyung Wang (Wang et al. 1987) conducted a DOE-sponsored intercomparison that focused on the treatment of the surface energy budget by three GCMs. The surface energy budget is the sum of energy fluxes of sensible heat, latent heat, shortwave and longwave upwelling and downwelling radiation. Wang and colleagues examined the surface energy budget simulated by state-of-the-art GCMs at the National Center for Atmospheric Research (NCAR), NOAA's Geophysical Fluid Dynamics Laboratory (GFDL), and NASA's Goddard Institute for Space Studies (GISS). The study covered the predictions of the models for climates with current levels of atmospheric CO₂ concentration (control climate) and for climates with twice the current levels.

Through this examination of surface energy budgets, the group was able to diagnose inter-model differences in surface temperature climatology and sensitivity to doubling CO₂ in terms of the processes that control surface temperature. The analysis compared the simulated balances by averaging the quantities of interest over a spectrum of spatial domains ranging from the entire globe to regions a few hundred kilometers across. The results of the analysis led to the following conclusions.

Principal Findings

1. For the global average control climate, the surface energy budget was dominated by longwave radiation (the "greenhouse" effect). The difference between predicted fluxes was a small fraction of the magnitude of the largest fluxes, but about 50% of the net radiation at the surface, and as large as any global-average seasonal change. This is a substantial difference between major GCMs, even for globally averaged values.
2. The change in global average surface fluxes calculated for a doubling of CO₂ agreed between models to about 10%. However, the noise level in global average control climate (the difference in net flux at the surface) was as large as the total effect of doubling CO₂, so that conclusions drawn from doubling CO₂ are suspect. Furthermore, global averaging obscures much larger differences occurring on the regional level.
3. Spatial variation of net longwave radiation at the surface is small compared to the spatial variability of near-surface air temperature and moisture, both of which exert significant control on the net surface longwave flux. The relatively small variability of the net longwave radiation appears to be due to compensation between temperature, atmospheric moisture and cloud effects.
4. Intermodel differences in surface flux changes for CO₂ doubling ranged up to 25% (100 W/m²) near the limits of polar ice caps. Differences in ice modeling among the models contributed strongly to the flux differences. Differences in control climate sea ice limits also contributed to the strong differences in flux changes.
5. Differences among modeled regional-level surface fluxes were attributed to variations and deficiencies in the parameterizations of meteorological physics.
6. Intermodel surface flux discrepancies for regional averages were as large as 50 W/m². This is twice the difference found for the

global average. Furthermore, models did not agree on the sign of regional flux changes for doubled CO₂ climates. Variations in the modeling of hydrology, especially clouds, appeared to account for these differences.

7. Quantities subject to orographic control showed relatively small intermodel discrepancy. That is, differences between models for the same region tended to be smaller than inter-regional differences. A notable example was that of precipitation patterns. Precipitation is indirectly related to the surface energy budget through the hydrological cycle.

The results of this study formed a basis for later GCM intercomparisons. The models examined were found to agree in some important respects. However, the intercomparison also found important differences among the models which have physical significance. The differences manifested themselves in critical quantities, such as precipitation, which have important regional consequences.

A GCM Intercomparison and the Earth Radiation Budget Experiment

The next intercomparison involves not only a comparison among models, but also a comparison with satellite data that is particularly well-suited to GCM formats. This effort, led by Robert Cess of SUNY, Stony Brook, discovered a three-fold variation in temperature sensitivities among 14 world-class GCMs (Cess et al. 1989). The variation was attributed primarily to differences in the representation of cloud climate feedback.

The dominant role of clouds in the earth radiation budget, while generally recognized, has only recently been quantitatively examined. Ramanathan et al. (1989) approach this issue by analyzing results from the Earth Radiation Budget Experiment (ERBE). They examined data for the planet as a whole and for a hypothetical, cloud-free planet. The latter data were

obtained by using only measurements for cloud-free conditions. This group found that on the global and annual average, clouds exert a short-wave forcing (due largely to enhanced albedo) of -44 W/m^2 and a longwave forcing (due largely to reduced infrared emission) of $+31 \text{ W/m}^2$ (radiative forcing is discussed in more detail below). These numbers are an order of magnitude larger than the incremental forcing due to a doubling of atmospheric CO_2 . Thus, relatively small errors in either or both forcing terms and their variations with changing climatic conditions could greatly affect predictions of the effects of trace gas increases. They clearly demonstrate the necessity of accurate treatment of cloud radiation in GCMs.

Cess et al. (1989) applied a technique to GCM models which resembles the techniques that Ramanathan applied to the ERBE data. By separately examining the model results for cloud-free situations and for the entire simulation, it was possible to determine both the clear atmosphere and the cloud contribution to atmospheric radiative forcing. Substantial variation from model to model in the sensitivity of mean global surface temperature to a change in direct radiative forcing was attributed largely to differences in the treatment of clouds by the different models.

Sensitivity to perturbations in radiative forcing is expressed by the climate sensitivity parameter λ as a relation between the global mean change in surface temperature T_s that would result from an arbitrary change in global mean radiative forcing G :

$$dT_s = \lambda G.$$

For T_s in K and G in W/m^2 , λ has units $\text{K}/(\text{W/m}^2)$.

For the clear-air subset of the calculations, the values of λ obtained with the several models exhibited a high model-to-model consistency. The mean was $0.47 \text{ K}/(\text{W/m}^2)$ and the standard deviation was $0.04 \text{ K}/(\text{W/m}^2)$ (less than 10%). In contrast, the sensitivity parameter, including cloud model effects, varied by almost a factor of 3 among the GCMs.

The dependence of the overall sensitivity parameter λ on the treatment of clouds in the several models was examined with respect to the cloud radiative forcing (CRF) of each of the models. The CRF is defined as:

$$\text{CRF} = (Q - Q_c) - (F - F_c)$$

where Q is the absorbed solar flux and F is the emitted infrared flux. The subscript c refers to the clear-air (cloud-free) situation. Each difference quantity within the parentheses represents the effect of clouds. The above quantities represent global average values.

Figure 5 illustrates the relation of the model-to-model variation in sensitivity (λ) to cloud radiative effects. In the figure, ΔCRF , which represents the change in CRF due to an arbitrary forcing G , is normalized to G . The model-to-model variation in λ is due largely to the differing magnitudes of CRF sensitivity in the models. The scatter about the regression line, which is of much lower magnitude, is due to differing clear-air sensitivities.

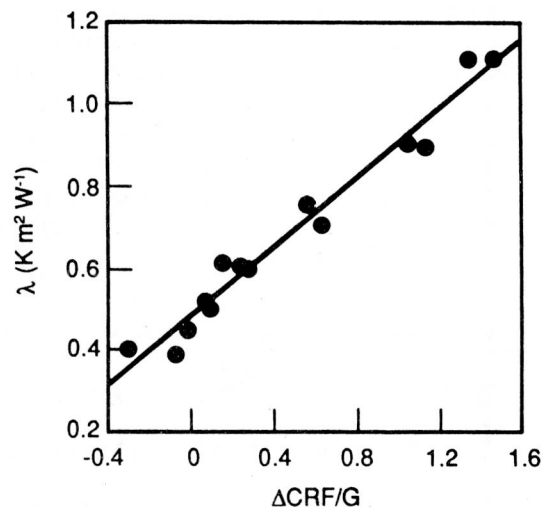

Figure 5. Cess intercomparison findings: model sensitivity vs. cloud radiative forcing.

Principal Findings

The primary conclusion of the intercomparison was that intermodel variations in the sensitivity of mean global surface temperature to changes in radiative forcing are mainly due to variations in the treatment of clouds in the GCMs. The effect of cloud treatment on the sensitivity was far more significant than any other contributing factors in the models.

The results shown in Figure 5 are a measure of the sensitivity of GCM calculations to parameterization of cloud properties affecting the Earth radiation budget. This sensitivity is substantial. For an increase in radiative forcing of 4 W/m^2 , corresponding roughly to a doubling of atmospheric CO_2 concentration, a climate sensitivity of 0.39 would result in an equilibrium increase in mean global temperature of 1.6 K. For a sensitivity of 1.11 W/m^2 , the corresponding temperature increase would be 4.4 K globally.

It is not currently possible to select among parameterizations of cloud properties to choose the "best" model. It is not even possible to confidently state that the actual response of the Earth climate to a perturbation in radiative forcing lies within the range represented by these calculations. It is this uncertainty in the radiative role of clouds, combined with a need for practical, predictive climate modeling, that is the principal motive behind the ARM Program. The intercomparison results of Cess et al. provide convincing evidence of the need to better define the properties of clouds as they affect the Earth's radiation budget.

The Intercomparison of Radiation Codes Used in Climate Models (ICRCCM)

The fourth intercomparison is actually one of the earliest conducted by DOE. ICRCCM is a program co-sponsored by DOE, the World Meteorological Organization (WMO), and the

International Radiation Commission (IRC). The late Fred Luther gave the best description of the rationale for the program:

"Since the transfer of solar and longwave radiation is the prime physical process that drives the circulation of the atmosphere and its temperature structure, it is natural that an evaluation of the modeling of physical processes important to climate begin with radiation."

(Luther 1984)

The purpose of this international effort was to evaluate and improve solar and longwave calculations used in climate models. The name is partly a misnomer because the comparison has involved many radiation models too detailed for use in a practical climate model.

The first ICRCCM workshop examined a total of 42 separate sets of model calculations. These were intercompared for 37 specified clear-sky control cases. Relatively large discrepancies (10% to 20%) among different models surprised the participants because the prevailing opinion had been that clear-sky longwave radiation was a solved problem. Suspecting that code or input errors might be responsible for the discrepancies, participants reviewed and modified their calculations. As a result, in some cases the range of discrepancies in model results became smaller. However, the main conclusions of the workshop report remained intact. They included a large spread among less detailed models (the kind actually used in climate and weather prediction models). ICRCCM disproved the assumption that the physics of molecular absorption and absorption line data were well understood

Principal Findings

1. Line-by-line models are in good agreement with each other to within a few W/m^2 (usually within 1%) when arbitrary line width cutoffs are universally applied. The ICRCCM concluded that: "Uncertainties in the physics of

line wings and in the proper treatment of the continuum make it impossible for line-by-line models to provide an absolute reference . . ." (Luther et al. 1988). Thus, no present-day model furnishes a reliable standard by which to judge other models, nor are appropriate data available.

2. There is no systematic difference between wide-band and narrow-band model results. However, there is a large variation among the band models. While average differences from line-by-line results range from 5 to 10%, the spread among the band models is several times larger.
3. Band model calculations of sensitivities to changes in absorbing constituents show poorer agreement with line-by-line results, and a much larger spread, than calculations of flux components. For example, when CO₂ is doubled, the median band model sensitivities differ by up to 18% from line-by-line values, while their spread is an order of magnitude larger.
4. In cases of CO₂ only and H₂O only, the spread in results among band models increases considerably compared to the case when all absorbing gases are included; this indicates that the success in the latter case is partly fortuitous because of the way absorbing bands overlap in the Earth's atmosphere.
5. For the longwave clear cases, with about 40 participants representing almost all the world's major modeling groups, ICRCM revealed intermodel disagreements in fluxes and flux sensitivity to constituent changes ranging from 30 to 70% (Luther et al. 1988). The disagreements are worst for single absorbing gas atmospheres, indicating that the better agreement found in the all-gas cases is partly accidental. Subsequent ICRCM calculations, involving cloudy longwave cases, and clear and cloudy shortwave cases, have revealed equally large or larger

disagreements, ranging up to 20 to 30% in fluxes and up to 70% in flux sensitivity to constituent changes.

6. Comparisons are still in progress for vertical profiles of radiative heating rates. Disagreements in radiative heating rates are expected to be larger than for fluxes, because heating rate is the derivative of flux and taking derivatives magnifies errors.

Implications of the ICRCM Results

A great impediment to improving line-by-line models is that there is no accepted theory for continuum absorption. Varanasi (1988) is pessimistic about the prospects for an accepted theory any time soon. Thus, modelers must rely on empirical formulations based on laboratory measurements. Almost all radiation modelers use the empirical continuum formulation of Roberts et al. (1976). However, new laboratory (Burch and Alt 1984) and field (Cutten 1985; Kneizys et al. 1984) measurements of the continuum show significant disagreements with the Roberts formulation. (It is common for the continuum numbers to change every few years.) Clough changed Roberts' formulation in the latest release of FASCOD, a commonly used high-resolution transmittance model, and developed a treatment of the continuum which is consistent with tabulated line intensities.

However, FASCOD had to be adjusted by using 10% more water vapor than measured to agree with high-resolution interferometer sounder (HIS) spectrometer measurements in the continuum. The HIS also revealed 60% errors in the foreign (air) broadened portion of the FASCOD continuum (Figure 6). The adjustments to the self-broadened water vapor coefficients are within the uncertainty of the radiosonde observations. Nevertheless, the results displayed in Figure 6 illustrate the continuing uncertainty about the accuracy of present-day empirical formulations of the continuum and about how to interpret the measurements on which they are based.

A great impediment to improving line-by-line models is that there is no accepted theory for continuum absorption.

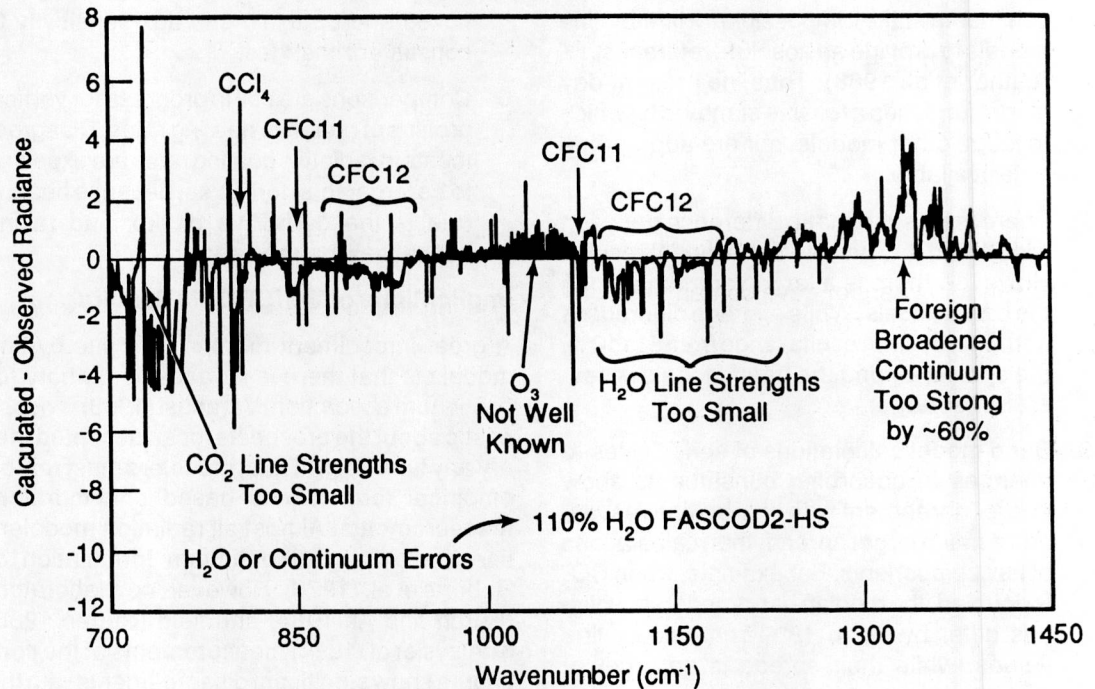

Figure 6. The difference between FASCOD2-calculated and HIS-measured radiance spectra found by Dr. William Smith, University of Wisconsin.

Two major components of the World Climate Research Program, TOGA (WCP-92 1984) and ERBE, have called for radiative flux accuracies of 10 W/m^2 or better. Existing radiation models cannot provide that accuracy. Except in unusual situations, typical sensible and latent heat fluxes are no larger than about 200 W/m^2 . The inter-model radiative flux disagreements are thus a significant fraction of normally observed energy fluxes. In the final analysis, it is these energy fluxes which control the climate.

These large disagreements among radiation computations do not manifest themselves as different computed climates because most climate models are tuned to give the "right" answer. This tuning is evident in the climate models' omission of water vapor continuum absorption through the 1970s. While the exact

magnitude and temperature-dependence of water vapor absorption are still outstanding problems, the existence of the absorption is indisputable. Omitting the continuum causes differences of roughly 80 W/m^2 in net surface longwave flux in the equatorial region, tapering off to zero at 60N and 60S .

Having identified these discrepancies, the ICRCM participants considered the usefulness of existing data sets for differentiating among the more accurate models. They concluded that the broad-band flux data gathered during typical field programs were not useful for this purpose for the following reasons:

1. Lacking any spectral resolution, such data do not allow the spectral bands causing the disagreements to be pinpointed.

2. The atmospheric profiles of physical conditions and composition were unknown. The resulting model-observation disagreements could be dismissed by invoking "hidden variables," like aerosol, or by adjusting the profiles within the large bounds of uncertainty.
3. Calibration of broad-band flux instruments is notoriously difficult, and notoriously bad.

After some 50 years of development, it is still impossible to push broad-band flux radiometer errors below 5%, even in the most capable hands. Broad-band flux measurements are averages of spectral radiance over all angles and wavelengths. When the same averaging is performed on the model results, it becomes almost impossible to trace the reason for the inevitable model-measurement disagreements.

Theoreticians believe their models have outdistanced current field data. They recognize that such data have bearing on other disciplines but consider them useless for doing research on radiation. The estrangement between the needs of modelers and the design of typical field programs is viewed with concern by the DOE.

Satellite observations may be considered as a means of constraining the various models. However, operational satellite radiometers tend to be poorly calibrated or uncalibrated and have been shown by underflights to exhibit drifts of 20 to 30% over just a few years. Atmospheric profiles are rarely taken at the locations of the satellite measurements. ERBE measurements are probably the most accurate and precise to date but, lacking spectral resolution, they are of little assistance in correcting the factors leading to intermodel disagreements. Also, satellite observations do not address the problem of surface energy budget and atmospheric heating and cooling rates.

Many spectrally resolved observations have been made from aircraft and stratospheric balloons, mostly to help better understand atmospheric

chemistry. These observations are sometimes of high quality, especially the spectra taken from stratospheric balloons to look for exotic molecules. But they cover only a portion of the spectrum, and profile information is lacking. Downward-looking spectra experience 'surface clutter' problems, making it impossible to distinguish effects of varying surface temperature and emissivity from defects in radiative model formulation.

Existing surface observations with reasonable spectral detail and covering most of the long-wave spectrum were reported throughout the 1950s, coincident with the development of Fourier transform spectrometers. These spectra were exhibited rather than compared with calculation, because atmospheric profiles were rarely measured concurrently. Highly detailed surface IR spectra are still occasionally taken by astronomers for their own purposes. Some observations are used for the study of the atmosphere (Stokes et al. 1983). There are, however, very few emission spectra of the atmosphere, notable exceptions being the recent observations reported by LaPorte et al. (1988) and Smith et al. (1990).

Laboratory spectroscopic measurements are another potential source of radiative transfer information. There are many practical difficulties associated with this approach to the problem. Primarily, there is a lack of interest in the spectroscopic community to study gases whose spectra are thought to be fairly well known. As a result, atmospheric radiation projects have suffered the loss of valuable research potential. However, laboratory spectroscopy alone cannot resolve all the relevant difficulties associated with the radiation codes.

Atmospheric conditions, especially cold temperatures and/or high humidities, are difficult if not impossible to reproduce in the laboratory. This is particularly true in the vital area of continuum absorption. Studies at relative humidities over 70% are a persistent problem. This is the

ARM will be directed at the improvement of GCM radiation and cloud models.

threshold for condensation on hygroscopic dust particles and therefore for fogging of optical elements. Furthermore, spectroscopists have reached an impasse in the area of line wings and the continuum that prevents progress in line-by-line modeling (Varanasi 1988).

Thus, conventional data sets, while interesting for some questions, cannot decisively resolve the widespread model disagreements. Climate modelers have reached a critical impasse. Their models disagree at a level significant for climate, yet no absolute standard exists to arbitrate the disagreements. Only empirical information can resolve the difficulties, yet existing data are inadequate for the task. Recognizing these facts, the radiation transfer community repeatedly recommended a sophisticated observational strategy:

"A dedicated field measurement program is recommended for the purpose of obtaining accurate spectral radiances rather than integrated fluxes as a basis for evaluating model performance."

(Luther 1984)

Following the 1988 ICRCCM workshop, the ICRCCM recommended, and the IRC and the WCRP endorsed, a second phase of the project. The primary purpose of the second phase would

be the validation of radiation models through comparison with observations. The objective was specifically to:

"Determine the requirements for real in situ data for validation of high spectral resolution models and other radiative transfer computations and explore ways of obtaining these data by either a specific dedicated measurement programme or by appropriate enhancement of other experimental activities, such as may be part of ISLSCP and ISCCP regional experiments."

The radiation instruments and atmospheric profiling technology necessary to address the problems raised by ICRCCM are now available. Furthermore, the experimental framework necessary to address those problems is compatible with that necessary to address the GCM cloud-radiation, prediction and parameterization problems. Thus, ARM has evolved to a program directed at the improvement of GCM radiation and cloud models. The details concerning the requirements to address these problems are discussed in the Experimental Design Section, and information concerning the necessary instrumentation is discussed in the Program Requirements Section of this report.

Program Requirements

ADVISORY

Program
Requirements

Program Requirements

ICRCCM identified a framework for measurements necessary to reduce the uncertainty of the clear-sky radiation problem. This framework involves the detailed measurement of the spectral distribution of radiation quantities and their dependent atmospheric variables so that the frequency integrated values might be accurately parameterized in terms of commonly measured atmospheric variables. The GCM intercomparisons suggest that the same type of experimental framework is essential to solving the GCM cloud prediction and cloud-radiation problems. That is, in order to attempt to parameterize the physics of the problem in terms of predicted, large-scale variables, it is essential to measure the subgrid-scale features of the problems.

In this section, the results of the GCM intercomparisons are translated into the requirements for the ARM Program. In setting these requirements, four issues are addressed. First, the results of the intercomparison programs are used to define basic goals for the program. Next, the context for the ARM Program is set in terms of unresolved subgrid phenomena. Thirdly, the experimental requirements for the ARM Program are discussed. Finally, the process of taking ARM experimental results and translating them into improved GCMs is presented.

The Goals of the ARM Program

The ICRCCM and other GCM intercomparison programs have highlighted an important area of scientific need associated with the understanding and prediction of global climate change. From the findings of those programs, the following scientific requirements emerge as the most critical:

1. A quantitative description of the radiative energy balance profile under important physical circumstances must be developed. The descriptions must come from field measurements and must be quantified at a level consistent with climatologically significant energy flows of 1 to 2 W/m².
2. The processes controlling the radiative balance must be identified and investigated. Validation must come from a direct, comprehensive comparison of field observations with detailed calculations of the radiation field and its cloud and aerosol interactions.
3. The knowledge necessary to improve parameterizations of radiative properties of the atmosphere used in GCMs must be developed. This requires intensive measurements at a variety of temporal, spatial and spectral scales. A major emphasis must be placed on the role of clouds, including their distribution and microphysical properties.

The Importance of the Radiation Field in Modeling Climate

From the results of the various intercomparisons of both GCMs and their constituent radiative transfer models, the importance of the radiation field is obvious. Current models indicate that if carbon dioxide were to instantaneously double, the outgoing longwave radiation leaving the atmosphere would be temporarily reduced by about 4 W/m², until the climate system adjusted to restore the balance. Most GCMs indicate that under these conditions, the globally averaged surface temperature would warm by 1.5 to 4.5°C before a new climatic equilibrium would be reached.

The models suggest that the climate system itself is very sensitive to the radiation budget. The CO₂ doubling experiments and the solar constant variation experiments represent changes of less than 2% in the net longwave radiation flux at the top of the atmosphere. The corresponding predicted zonally averaged changes in average annual surface temperature of 2 to 8°C demonstrate the high sensitivity of the GCMs to such perturbations in forcing. The models of the Earth's radiation budget in GCMs must be correspondingly sensitive if the skill of the GCMs in predicting climate change is to be improved. If the radiative transfer is not properly handled, then the models will have improper base or control climates that form the basis for the climate perturbation experiments. Presently, the sensitivity of a GCM to the perturbation caused by a CO₂ doubling, expressed in degrees of average temperature change, is itself a function of the base climate. This clearly demonstrates the need to reduce the uncertainty associated with inaccurate models of radiative transfer processes within the GCMs.

There is more at issue than the sensitivity of the climate systems to radiative forcing. The inter-comparison studies illustrate two other important points about the need to correctly model the atmospheric radiation field. First, the GCM inter-comparison has quantified the critical role that clouds play in regulating the transfer of both longwave and shortwave radiation within the troposphere. Changes in the distribution and physical characteristics of clouds can have major effects on climate sensitivity. For example, it can be estimated that a 10% increase in the cloud fraction would completely counteract the radiative impact of a doubling of CO₂. Similarly, small changes in typical cloud altitude or liquid water content could have comparable effects, since these properties affect the emissivity and radiating temperature of the cloud. Therefore, it is essential to properly account for the interaction of clouds with radiation to predict climate change reliably.

Finally, the radiative transfer problem is not simply an energy balance problem. The so-called "greenhouse effect" is actually a spectral redis-

tribution process. The radiation absorbed by carbon dioxide and other radiatively important trace species is absorbed in particular parts of the spectrum. The importance of carbon dioxide in the greenhouse warming process arises because it absorbs near the peak of the black-body radiation curve for the atmosphere. The absorption of energy at these wavelengths alters the temperature of the surface and the atmosphere. The increase in temperature leads to an increased radiative flux in the "transparent" regions of the spectrum.

The "Figure of Merit" for the ARM Experiment

These considerations suggest that a comparison between the radiation field calculated in a model and actual observations of the radiation field could be a very sensitive test of the efficacy of the modeling process. The ARM experiment will be built around just such a comparison, with two goals in mind. First, it will attempt to improve the treatment of radiative transport in GCMs for the clear sky, general overcast, and broken cloud cases. Second, it will provide a testbed for cloud parameterizations used in GCMs. In both cases the "figure of merit," or measure of the quality of the models, will be the ability of the model to reproduce observed wavelength and direction dependent fluxes of longwave and shortwave radiation.

The Resolution and Parameterization Problem

The observational figure of merit can be tied to the improvement of GCMs through an understanding of the "parameterization problem." The essence of the ICRCM process and the other intercomparison projects strongly support the view summarized by Schlesinger and Mitchell (1985) in the State-of-the-Art Report "Projecting the Climatic Effects of Increasing Carbon Dioxide."

"...it is now time to begin the very difficult task of systematically validating the GCM parameterizations of subgrid-scale processes."

The term "parameterization" has been frequently used to describe what is actually a model within a model. A parameterization is a description of a physical process or group of interrelated processes that is used to predict a quantity needed by a GCM or other sophisticated computer model during the course of a simulation. In order to validate, or more correctly, to evaluate the accuracy of these parameterizations with measurement programs, the way in which GCMs implement the parameterization must be understood.

Numerical radiative transfer and general circulation models represent continuous meteorological and radiation fields by discrete approximations. These approximations can only define the fields on a finite scale. The smallest resolved scales are called the "grid scale," while processes occurring on smaller, unresolved scales are called "subgrid scale." The most obvious way to represent a three-dimensional spatial variable is by specifying the values of the field on a discrete grid mesh, hence the term subgrid scale. Resolution issues, however, are not confined to spatial variability. In GCMs, finite time intervals and band resolution of radiative properties that are functions of wavelength are also important. Parameterizations are needed to describe the effects of unresolved processes on the resolved scale fields. Conversely, the evaluation of models from instantaneous point measurements requires additional scaling considerations.

The assumption in the GCM parameterizations is that the small-scale effects can be determined from the properties of the resolved scale fields. Because the model is designed to simulate only the resolved scale fields, a complete description of the unresolved physics is not required. However, the manifestation or net result of the unresolved physics on the larger, resolved scale must be accurately predicted from the information available within the model.

It is best to consider resolution issues in terms of the different domains in which the model fields

are defined. Meteorological fields are defined in the space and time domains and radiation fields require the addition of the electromagnetic wavelength domain as well. The process of parameterizing subgrid-scale processes for inclusion in a GCM therefore needs to be undertaken with care. Unless the critical physical elements of the system on the resolved scales are preserved, GCMs will be unable to achieve the capability for regional prediction necessary for policy formulation. It is also essential that the parameterizations change in a physically correct manner as the climate changes.

The emphasis of the ARM Initiative will be on radiation fields both on the resolved and subgrid scales. Correctly incorporating the effects of subgrid-scale variability on the resolved scale will be necessary, as will the interpretation of GCM results in terms of local meteorological patterns. The problem of relating local measurements to values appropriate to grid scales of GCMs is a crucial aspect of ARM and its interpretation of model results. Of particular importance in the ARM Program are the resolved-scale effects resulting from the interaction of the subgrid-scale radiation field with the subgrid-scale cloud fields.

Parameterization in the Spatial Domain

The problem of parameterizing cloud properties is particularly difficult because it involves both meteorology and radiative transfer. The presence of unresolved (that is small) clouds complicates this problem. Unless the cloud bank uniformly covers the area of the GCM grid cell, the radiation cannot be uniform and will vary over the volume. The interaction of adjacent grid volumes with subgrid-scale clouds further complicates the calculation. The subgrid regions with clouds in them will have altered radiative fluxes and atmospheric heating. The effect is nonlinear, and depends on the detailed vertical and horizontal distribution of the clouds.

It is essential that resolved radiative fluxes produced by a GCM parameterization be consistent with the means and variations seen in reality.

The problem of parameterizing cloud properties is particularly difficult because it involves both meteorology and radiative transfer.

The existence of an extended data base providing the fundamental information on the statistics and variations of the atmospheric structure and radiation field is a prerequisite to the creation and validation of a successful parameterization of the subgrid radiative transfer problem, including clouds.

Temporal Resolution

The parameterization of climatological processes in the time domain has several important features. The above discussion of the parameterization of cloud effects in the spatial domain is one feature. Within a grid cell the clouds and other small-scale phenomena create fluctuations in the radiation field. It is important that the temporal domain over which the statistical properties are described be appropriate. The statistical properties of the cloud field that the parameterization of the field preserves must include the essential elements. For example, a model may preserve fractional cloudiness but not the average surface heating rate. Such a model would fail to treat adequately the temporal parameterization.

Temporal resolution is also important for the experimental verification of radiative models. Radiative processes are characterized by the time scales required for the atmosphere to change its thermal structure or its cloud distribution. It is the integration of these processes over the meteorological time scale that is important. This can be as small as several minutes for cloud properties. Therefore, there is a particular need for observations from remote sensing instruments to supplement direct but infrequent sampling measurements (e.g., those taken with radiosondes). In addition, the range of physical conditions that control the transfer of radiation through the atmosphere can be observed over time. A long-term measurement system, with carefully chosen sites, would enable exploration of the full domain of the radiative transfer codes and their parameterizations.

Electromagnetic Wavelength Resolution

One of the most critical parameterizations in GCMs is the loss of spectral resolution in the radiative transfer parameterization. This problem is also encountered in the broad-band radiative transfer models. From the standpoint of the GCM itself this is a perfectly appropriate parameterization. However, the details of the way in which greenhouse gases affect the energy balance of the atmosphere are a strong function of wavelength.

The CO₂ and other trace gas radiative forcing-feedback problem depends not just on radiative forcing, but on radiative forcing in particular spectral bands. The forcing caused by the increased absorption in certain narrow regions of the radiation spectrum triggers nonlinear responses in other spectral regions. Several trace gases (CH₄, N₂O, CFCs, etc.) theoretically are capable of having the same greenhouse effect in very low concentrations as the increases projected for CO₂ between now and the year 2000 (WMO 1983). While the GCMs require total energy balance in the calculations, spectrally resolved measurements give important insight into the processes responsible for radiative forcing and the associated radiative feedback mechanisms.

As discussed in the Background Section, a standard for the validity of these parameterizations is the comparison of broad-band radiative results with those from line-by-line calculations. This is an important comparison, but line-by-line calculations are also dependent upon many approximate experimental and theoretical results. There is, therefore, a fundamental need to understand the validity of both the broad band and line-by-line calculations.

Also demonstrated in the Background Section was the need to advance technology applied to atmospheric radiation field measurement that has changed little during the past 10 to 20 years.

One of the most critical parameterizations in GCMs is the loss of spectral resolution in the radiative transfer parameterization.

However, radiation models have advanced greatly in sophistication and lack any real challenge from the experimental side. Many theoreticians believe that their models are vastly superior to the available broad-band-flux field measurements. As a result, there are relatively few systematic comparisons of models and observations. A rigorous program of observations is needed to change this situation and to validate the models. By using the technological advances of the past 20 years, (primarily in remote sensing equipment, data management and spectral radiance measurements), field experiments can narrow the gap between what we know to be important (accuracy in radiation terms on the order of 1%) with what has actually been measured.

The Basic Experimental Approach to ARM

With this understanding of the parameterization problem, it is important to outline what the various parts of the experimental program will be. Here, the ARM Program falls naturally into three parts driven by a straightforward experimental approach. First, in order to focus on the radiation field and its treatment, only the radiative models will be tested. The second part considers the additional observations needed to develop and test parameterizations of the radiation model on such scales as a satellite footprint or a typical GCM grid scale (30 to 200 km). Third, the design of the experiment addresses cloud parameterizations in GCMs.

Test Radiative Models

Like ICRCM, the radiative models will be drawn from the full suite of available radiation codes, each being used to gain insight into the parameterized GCM radiation models. ARM will integrate actual meteorological and physical

measurements to drive the codes. This approach is shown schematically in Figure 7. The critical question is therefore, what non-radiometric measurements are required by the radiative models in order to predict the wavelength-dependent fluxes. Examples of the observations required could be as simple as temperature profiles and profiles of water vapor, or as complicated as the three-dimensional structure of the cloud and aerosol fields in the vicinity of the observing station.

Expand to GCM and Satellite Scale

Field measurements can focus on the lower part of the atmosphere most difficult for satellites to measure. An experiment beginning now could span several satellite generations from NIMBUS-7 and ERBE to EOS. Satellite measurements will form a critical part of our understanding of the Earth's radiation budget over the next several decades. Therefore, the ability of ARM to provide calibration for energy budget calculations will be especially valuable.

GCM Cloud Parameterization

For this latter point it is useful to imagine how the results of this program can be used in improving GCMs. In particular, it is likely that there will be convergence of the models and measurements at wavelengths and physical scales of far greater resolution than can be used in a GCM. It is then legitimate to ask which features need to be retained as the resolution of the models is reduced in order to preserve the basic physics and energy budget in the more detailed case.

The design of the experiment addresses cloud parameterization in GCMs in the following way. As described earlier, and as noted by Gates (1985) and Schlesinger and Mitchell (1985), cloud formation in a GCM is a matter of varying

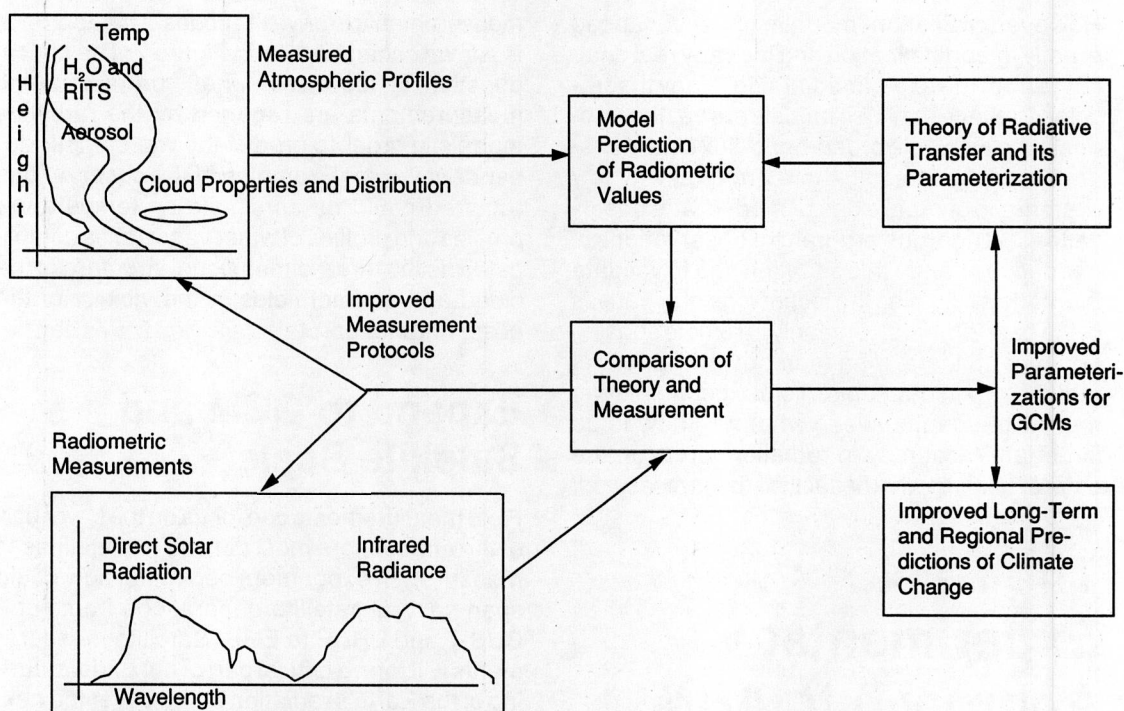

Figure 7. The ARM experimental approach as applied to the study of the radiation field.

cloud properties in a grid cell in response to a given set of physical conditions. In ARM these parameterizations can be tested using observed rather than calculated sets of physical conditions. The ability of the model to predict the observed radiation field continues to be the experimental figure of merit. This is an important test, because although clouds are an important climate feedback mechanism, the primary consideration within the context of ARM is their effect on the radiation budget.

The underlying motivation for all three primary objectives is to provide radiation models with an incisive comparison with measurement. By forcing the models to conform with well-known current conditions, they may be expected to show improved agreement with each other and improved predictive ability for potential climate change. In order to constrain the models to a useful level of accuracy, it is necessary to improve the quality of radiation field observations so that models can be tested to 1% accuracy, a level that is climatically significant.

Constraining the Radiation Models

One of the three major goals of ARM is to improve the quality of radiation models under clear sky, homogeneous cloud, and broken cloud conditions. In this section we will describe which basic radiation measurements could be compared with theoretical calculations. We will also delineate measurements needed to observe the atmospheric properties that control radiative transfer under the three broad classes of meteorological conditions noted above. The detailed, planned measurements of ARM will be discussed in the Experimental Design Section.

Radiation Measurements

There are five classes of radiation measurements which could be used to constrain radiative models:

1. Spectral Radiance

There are several reasons why spectral radiance is one of the most important measurements to consider. First, spectral radiance, not broad-band flux, is the quantity actually predicted by radiative transfer theory. Comparing it to theory is much more natural and informative. Second, in measuring radiance, photons are collected from specific directions. It is therefore possible to design an experiment so that the radiance is measured in directions in which the atmospheric state is known.

Third, the true test of a theory is its ability to predict correctly the detailed functional structure of some variable. The more complicated and structured the functional dependence, the better the test. Most of the past investigations have measured broad-band fluxes as a function of time or have measured broad-band fluxes as a function of altitude. The flux-time observations, while full of structure, have been published rarely and represent some poorly understood integration over the turbulent structure of the atmosphere. The flux-altitude measurements are routinely published, but are fraught with uncertainty because of the time lag for an airplane to ascend and descend. In addition, they are almost featureless and are a poor test for models. A linear or quadratic function of pressure will generally fit them quite well (except near cloud boundaries). Although a model that uses such an analytic fit may produce "reasonable" results, its accuracy may not fit the requirements needed for climate simulations.

As noted previously, a real advantage of measuring the detailed spectral radiance is that not only does it represent a fairly structured functional relationship, but the relationship also reflects the basic physics of radiative transfer. Therefore the comparison of the observations and theory can provide insight into the critical physical processes

whose effect needs to be preserved as the radiation field is parameterized for inclusion in GCMs. If the wavelength dependence of the spectral radiance can be measured with an absolute accuracy of 1 to 2%, incisive testing of models should be possible.

2. Broad-Band Fluxes

Broad-band radiometric fluxes are effective measurements if used under appropriate circumstances. Total integrated fluxes can be useful in two ways:

First, as noted above, the time variation of the integrated flux can give useful statistical information concerning important phenomena. In particular, the basic statistics of the variation of total flux can be a useful measure of the performance of cloud parameterizations. Second, these simple measurements can be made in relatively unattended mode and can be used to characterize the spatial distribution of fluxes. Broad-band fluxes can be difficult to calibrate. However, operated in modes in which their precision (0.5 to 1.0%) rather than their accuracy (5 to 7%) is the critical measure of performance, these measurements can usefully constrain radiative transfer models.

3. Net Fluxes

One way of circumventing the limitations associated with the absolute calibration of broad band flux measurements is to modify the observing scheme such that the measurements are net, or difference, measurements. In principle these measurements can achieve greater accuracy than the direct measurements. However, recent results from ISLSCP suggest that one class of these measurements, net surface radiation, can suffer from large systematic errors. Improvements in instrumentation and methods may be able to overcome these problems. Since net radiation is often a modeled quantity, net flux measurements will form an integral part of the measurement strategy.

4. Flux Ratios

Like net flux measurements, flux ratio measurements can circumvent the problems of the absolute calibration of the raw measurements. An example of a flux ratio measurement is the so-called "ratio of direct to diffuse radiation." This measurement is generally defined as the ratio of the flux emitted from the sun and a small surrounding solid angle to the total flux on a horizontal surface. It is a sensitive measure of the effectiveness of a radiative model's treatment of shortwave scattering.

5. Polarization

Polarization, including linear polarization and circular polarization, is not a common measurement taken of the atmosphere. However, like the ratio of direct to diffuse radiation, polarization measurements can be a very sensitive measure of the treatment of scattering processes. Most modern methods for measuring polarization operate on the principle of taking flux differences and flux ratios. These approaches make sensitive polarization measurements simple to obtain.

However, in spite of the advantages polarization measurements might offer, there are few systems available for measuring the polarization of atmospheric fluxes. Polarization parameters are also not generally carried through most radiative models, although some of the more sophisticated codes can predict polarization. A key question concerning polarization is whether radiative models with this level of detail will contribute substantially to improved parameterizations of the radiation field. The ARM experiment will include sufficient polarization measurements to address this issue.

Characterizing the Atmosphere

The basic design of ARM expects that models of the radiation field will be based on observations of the state of the atmosphere rather than on

predictions. There are two basic approaches that can be taken to specify which atmospheric observations are required to support models of the radiation field. The first approach would be to ask which set of physical conditions would a GCM either use now or anticipate using to predict the radiation field at some time in the future. The second approach would be to ask which observations in general would be required to predict the radiation field, without restricting our considerations to the necessarily limited set of physical conditions available to a GCM.

In setting the requirements for the atmospheric observations we have chosen the latter approach, making sure that the GCM requirements are a subset of the ARM observations. The reason for this choice is very simple. As described by Gates (1985) the development of a GCM is a matter of choices. The choices reflect the necessary trade-off between capturing the critical physics and the computational limitations of modern supercomputers. Since ARM will guide the treatment of the radiation field in GCMs, it too must contend with this trade-off. In essence, ARM's approach is to fix the resolution and computational characteristics and then to seek the appropriate physics of radiation and cloud processes.

The set of observations required to specify the atmospheric state fall into the categories of basic meteorological measurements, atmospheric composition, geometrical structure and surface properties.

Basic Meteorological Measurements

The critical consideration for the basic meteorological measurements is that the measurements should be made on a time scale appropriate for the study of radiative properties. This implies that instantaneous measurements, probably remote-sensing-based, are a necessary addition to direct sampling approaches associated with sondes. The measurements include: pressure as a function of altitude, temperature as a function of altitude, and the three-dimensional velocity field. These observations need to be

... measurements should be made on a time scale appropriate for the study of radiative properties.

made on cloud time scales, typically between several minutes and several hours.

Atmospheric Composition

The determination of atmospheric composition includes: the concentration and phase distribution of water, the distribution of other trace gases, and the size distribution and properties of aerosols and cloud droplets. Like the basic meteorological measurements, these properties should be specified on time scales associated with the radiative processes, suggesting a general requirement for remote sensing approaches. However, in-situ measurements of cloud microphysical properties, such as drop size distribution, water and ice content, and aerosol composition, will also be important.

Geometrical Structure of the Atmosphere

The need for the three-dimensional structure of the atmosphere in the vicinity of the radiation measurements arises for two reasons. The first is that the investigation of the trade-offs associated with the parameterization of the overall three dimensional structure of the atmosphere is one of the objectives of the project. One therefore needs to specify that structure with sufficient detail to allow the examination of the physical process on a variety of physical scales. This structural specification can range from a detailed three-dimensional picture of the radiation to observational characterizations of the horizontal homogeneity of a stratiform cloud. Other properties specifically related to the broken cloud case are fractional cloudiness as a function of height, cloud overlap, and the aspect ratio of cumulus clouds.

The second consideration is directly related to the study of clouds. Many of the important properties of clouds and their radiative effects require knowledge of the shape (as opposed to the composition) of the clouds. A method of

delineating the "outer surface" of clouds will be important for examining their effects on both the longwave and visible parts of the spectrum.

Surface Properties

Finally, it is important to remember that the radiative transfer problem has two important boundary conditions, the radiation incident at the top of the atmosphere and the properties affecting radiative transfer at the Earth's surface. The two most important properties for the specification of the radiation field are the surface reflectivity and the effective surface radiating temperature ("skin" temperature). It should be noted, however, that the surface reflectivity or albedo is a function of the wavelength and angular incidence of the radiation, and of variable surface properties such as wetness and ground cover.

Analysis Requirements

With the observational requirements delineated, the second part of the ARM Program is the process of connecting the observations to the computational models. This process involves the understanding of how the basic physics of radiative transfer is formulated in a numerical framework. The analytic considerations—how the modelers might use ARM results—provide further guidance on the experimental design. In particular, these considerations will help assign priority to particular observations and suggest the accuracy and precision required of the measurements.

The basic physical principles governing the transfer of electromagnetic radiation are well known. However, the atmospheric science community uses a wide variety of techniques and basic spectroscopic data in its calculations. The objective of ARM is to develop accurate parameterizations of the detailed physics for use in GCM's that will apply to the full range of atmospheric

conditions. The confidence placed in the parameterizations, however, will depend on the ability of the detailed radiation models to simulate, and predict accurately, the observed radiation fields. The analysis of periods of transition (clear to cloudy conditions, for example) is particularly important.

Direct Comparison of Observations with Model Calculations

The calculation of the flux of radiation at any altitude at a given time requires knowledge of the instantaneous vertical and horizontal distributions of temperature, absorbers and scatterers. The accuracy with which detailed models can predict the wavelength distribution and integrated radiative flux can be determined with the aid of instantaneously measured distributions of radiatively important variables.

The basic analysis necessary to achieve this is straightforward. It entails comparing integrated radiance and flux observations with those calculated by detailed models of the basic radiation physics using simultaneous observations of the radiatively important variables as inputs. However, the hierarchy of issues to be addressed and the analysis techniques to be employed depend upon the degree of aerosol concentration and cloudiness.

The detailed analyses will require a variety of line-by-line radiation models such as FASCOD3 (Clough et al. 1989), GENLN2 (Edwards 1989), and others used in the ICRCM calculations (see Luther et al. 1988). For the solar spectrum, the analysis should apply a line-by-line, adding-doubling technique of the type developed at GFDL. These models are desirable for their detailed physics and their widespread use among modelers in the development of GCM parameterizations. They are based on parameters derived from laboratory observations and spectroscopic theory. They also employ some parameterizations intended to incorporate unknown physics, such as the so-called water

vapor continuum. The comparison of calculations from these models with measured radiance from the overhead vertical column would indicate potential improvements in spectroscopic theory and laboratory observations.

Clear-sky calculations provide the background against which all more complicated cloud and aerosol cases are contrasted. An analysis using relatively clear atmospheres is therefore important to address the large disagreements among models which ICRCM found for clear cases. For homogeneous overcast cloud cover conditions, the analysis must specify the three-dimensional distribution of the atmospheric radiative properties. This will make computation more difficult because multiple scattering becomes important for both the long- and short-wave problems. For quasi-horizontally homogeneous cases, the required analysis will closely resemble that for clear-sky conditions.

The analysis scheme for the more complicated partly-cloudy cases will be developed on the basis of input from the ARM Science Team. The analysis should test and improve radiation models for the full range of atmospheric variability. Therefore, this scheme will need to include a variety of simulations of random and regularly distributed cloudiness conditions with varying geometries. Accurate radiative transfer models should be examined to arrive at the specific sampling and analysis strategy. High absolute accuracy is necessary to determine the energy budget at specified levels, and high relative accuracy is required for the calculation of flux ratios.

The comparison of model results with observations must be performed on a continuing, real-time basis throughout the experiment. The analysis will require documented and/or operational versions of narrow- and broad-band radiation codes from various climate models. For those models not being tested operationally, observed data will need to be distributed to investigators wishing to participate. Because each model calculates radiance in different spectral intervals, spectral radiances should be computed at the highest possible resolution.

The comparison of model results with observations must be performed on a continuing, real-time basis throughout the experiment.

Appropriately averaged spectral observations will be required for comparison with the model outputs.

Obtaining Parameterizations from ARM Measurements

The spatial scale anticipated for a reliable climate predictive model is on the order of 50 km in the horizontal, with between 20 and 30 vertical levels. This is the largest scale at which one marginally can resolve regional effects. Climate effects in regions that are 500 to 1000 km in scale cannot be predicted with confidence unless the climate model scale is much smaller. Further, 50 km is the smallest horizontal cell size for which cloud microphysical parameterization is essentially complete. As the cell size grows from a small fraction of a kilometer, more and more microphysical processes are necessarily parameterized, until at the scale of tens of kilometers, virtually all physical processes are parameterized. Since it may be impossible to calculate all of the microphysics necessary for climate prediction in the foreseeable future, even with computer throughput tens of thousands of times that available today, it would not be fruitful to attempt a spatial resolution much below 50 km.

The nominal 50-km climate prediction grid size is within a factor of two of the 30-km nadir pixel size of the ERBE satellite, to which the ARM observations will be sized. Models built to predict climatically necessary parameters for the ARM site, including its outlying stations, will automatically be near the appropriate scale size for climate prediction, and thus will automatically have most parameterizations done properly. This virtually eliminates one step in the process of deriving models for climate codes from the ARM data.

The process of designing new GCM parameterizations from ARM site data will then consist of: 1) constructing models capable of predicting observations at an ARM site, 2) combining the

models into a set of models in which all climatically significant variables are parameterized, 3) generalizing the models to predict at all ARM sites (as well as at other sites), 4) eliminating parameters that are unnecessary for climate predictions, 5) retesting the models with data from all ARM sites to prevent special conditions applicable to only some of the ARM sites from being built into the model, and 6) checking to be sure the parameterizations in the models scale up from the 30-km site size to the approximately 50-km GCM grid size.

Step 1 will be accomplished for the most part by experimentalists and analysts associated directly with the ARM measurements. The remaining steps will have to be done by modelers or others interested in the problem. A major section of the ARM Science Team will be devoted to designing and implementing these steps.

A crucial aspect of this analysis will be to construct a model valid for a three-dimensional grid cell from the more limited data available from an ARM site and its surroundings. It should also be recognized as likely that data obtained from the ARM Program will suggest new parameters to be modeled as well as changes in the way current GCM parameters are modeled. It is also likely that the analysis of models will show that new, or more thorough, measurements will have to be made in the ARM Program. ARM may therefore be viewed as a continuing and evolving experiment.

Parameterization, Testing and Development

As stated previously, one objective of the ARM experimental approach is to serve as a testbed for the methods developed to parameterize clouds in GCMs. Currently, clouds are incorporated in GCMs in one of two manners. In the first, all cloud properties are fixed, including the cloud amount and the cloud radiative properties (i.e., reflectivity, absorptivity, transmissivity), usually according to cloud type (e.g., low, middle, or high). The clouds are assumed to either

completely fill the grid box in given layers, or randomly overlapped partial cloud cover is assigned to several layers. The second general approach is to predict the fractional coverage of different cloud types as a function of model parameters, such as the relative humidity. There are a few techniques to calculate the cloud liquid water content, which in turn is used to predict the bulk cloud radiative properties.

From the perspective of ARM, the primary importance of cloud parameterizations is through the incorporation of those parameterizations into the radiation codes. There are several approaches that can be taken as starting points for cloud parameterization. Each of these views has special value in the process of developing cloud parameterizations. The approaches are 1) developing the parameterization from basic cloud microphysics, 2) using data to develop empirical cloud parameterizations, and 3) more speculative ad hoc modifications of the current fairly crude approach to parameterization used in GCMs. ARM needs to support the testing and exploration of each of these, as well as new ones

proposed by the Science Team. Figure 8 illustrates the relationship of the cloud parameterization activity with the radiation modeling and observation programs.

Microphysical Parameterizations

When modeling cloud microphysics, it is useful to distinguish between stratus and cumulus clouds. Highly elaborate cloud-physics formulations (Lee and Hong 1987; Lee 1989), which contain high levels of phase disaggregation with numerous categories of cloud drop sizes, ice crystal types and raindrop sizes are possible. However, these may lead to unmanageable numbers of species combinations in the form of simulated dependent variables. There is a pressing need, therefore, for optimization of the mathematical descriptions of cloud physics parameters and processes. The mathematical formulas should be simple but sufficiently accurate, in order to allow efficient incorporation in GCMs.

The microphysical approach consists of four steps: 1) evaluating initial phase interaction

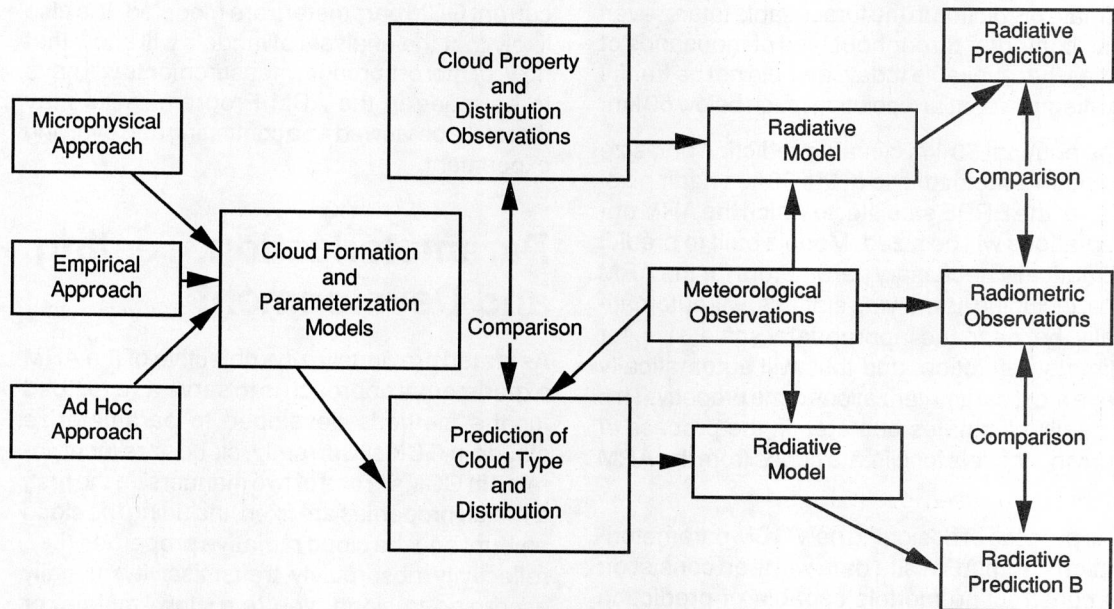

Figure 8. Linkages of the cloud parameterization, radiation modeling and observation programs. The critical activity of the various comparisons is hypothesis testing. Although not shown, the results of the comparisons feedback to the various modeling programs.

schemes based on formulas currently available (Kessler 1969; Ogura and Takahashi 1971; Berry and Reinhardt 1974; Lin et al. 1983); 2) deriving optimized formulas from data generated by numerical simulations of clouds in a variety of atmospheric conditions (Lee and Hong 1987; Lee 1989); 3) performing comparison studies and sensitivity analyses; and, 4) applying new parameterizations to a fine-grid mesoscale model for derivation of cloud cover in terms of bulk atmospheric parameters readily available in regional and large-scale models. These steps should be able to provide an advanced set of cloud-physics parameterizations including transformation rates applicable to vapor-liquid-solid phase under variable atmospheric conditions.

Empirical Parameterizations

As for the microphysical parameterizations, it is convenient to divide cloud parameterizations into two types, cumulus parameterizations for convective clouds and stratiform parameterizations for stable clouds. Most cumulus cloud parameterizations were developed for mesoscale models and model the influence of latent heat releases within clouds on the resolved-scale dynamics and transport (e.g., Kuo 1974; Anthes 1977). However, the best known parameterization, that of Arakawa and Schubert (1974) was developed to describe tropical cumulus transport of heat, momentum and water for the UCLA GCM.

These models are used when the atmospheric temperature and moisture structure will allow convective clouds to develop over subgrid regions and are not usually concerned with radiation properties. The parameterizations predict cloud fractional coverage and the concentrations of water vapor, liquid water, and ice as a function of height. Additionally subgrid-scale fluxes of heat, momentum, water vapor and liquid or solid water are also diagnosed. The parameterizations are based on an ensemble of "typical" clouds occupying the grid region. A key assumption is that this ensemble can be predicted from the large-scale resolved quantities such as mixing ratio, velocities and potential temperature.

Stratiform parameterizations are used when an entire grid cell becomes saturated at one or more levels, but the atmospheric stability is such that convective clouds will not develop. In this case, a stratiform cloud layer is assumed to occupy the entire layer over the grid region, and the cloud microphysics are parameterized to predict cloud properties such as liquid water, ice and vapor concentrations in addition to precipitation. The stratiform models are very similar to those used in GCMs. Those models take into account the radiative effects of the resulting cloud, but do not typically model the radiative feedback processes that influence cloud evolution or structure (Lin et al. 1983).

GCM Parameterizations

To simulate properly the interaction of clouds with radiation, the radiation codes must not only be properly formulated, but the input to these codes must be accurate. This means that GCMs must accurately predict the cloud distribution and the physical properties of the clouds, including their liquid water content, cloud drop size distribution, and some measure of their subgrid-scale "patchiness." In all of these respects GCMs are currently deficient. It is generally felt that the inability to predict realistic physical properties of clouds, including cloud fraction, is responsible for a large measure of the differences among GCMs. This leads in turn to much of the uncertainty in the model estimates of the climatic impacts of increasing concentrations of carbon dioxide and other greenhouse gases.

A fundamental goal of the ARM Program is therefore to improve GCM capabilities in providing the cloud characteristics needed by the radiation codes. In particular, the measurements of the physical characteristics of clouds, such as liquid water content, cloud condensation nuclei (CCN), and cloud drop size distribution, will provide an observational basis for development of new parameterizations so that GCMs will be able to represent more realistically the physical properties of different types of clouds. The ARM program will, for example, provide valuable information concerning the total amount of liquid

water in various types of clouds, along with characteristics of the individual cloud particles, including size distribution, and number density of both the ice and liquid fraction of the clouds. These observations will be used to verify GCM parameterizations in which these cloud characteristics play an important role in determining the cloud radiative properties.

The ARM Program promises to contribute significantly to improvements in the characterization of clouds once they are formed in GCMs. The prospects for contributing to improved parameterizations of cloud formation itself are less certain. Accurate predictions of cloud formation in GCMs is recognized to be one of the major shortcomings of these models. There is presently very little theoretical work on which predictions of subgrid-scale cloud cover can be based. The usual procedure is to simply prescribe a certain fraction of the grid cell as being cloud covered (depending on which type of cloud has been predicted to occur), although a few ad hoc parameterizations have also been tried.

It will take considerable theoretical work and the development of new parameterizations before it can be determined what measurements are needed and would be most appropriate for verification of cloud predictive schemes in climate models. Nevertheless, extensive measurements may provide the insight required to develop better theories. The process of improving parameterizations must be an iterative one in which observations yield better theories that require more measurements for verification. Extensive analysis of data collected during the ARM Program will provide a valuable resource for improved parameterizations. As new parameterizations of cloud formation in GCMs become available, these formulations will be tested against the ARM data set. In general, the proposed measurements at relatively few ground-based locations cannot assure the complete global cloud characteristics needed to verify global climate models. This inherent incompleteness of the ARM Program can be minimized by careful choice of sites and campaigns with the mobile site. Further, the ARM Program will provide extensive verification for grid-scale processes

within GCMs and will coordinate its activities with satellite-based remote sensing programs to extrapolate its results to larger scales. The lack of complete geographical coverage will also be offset somewhat by an ability to substitute temporal statistics for spatial statistics. In this way cloud cover on small scales may be more fully characterized.

Measurement Accuracy Requirements

The examination of the sensitivity of radiance and flux calculations to possible errors in meteorological data is far from complete. However, we have estimated the sensitivity of the long-wave flux and the spectral flux (or intensity) in 20 cm^{-1} intervals to the range of possible errors that might arise from uncertainties in different measurement systems (see Figures 9 and 10). In general, uncertainties in the water vapor field dominate the spectral effects in the very transparent regions from 800 to 1200 cm^{-1} , whereas temperature errors dominate the more opaque regions.

In order to keep the uncertainty of the calculated radiances in the 10 micron window region to the order of 5% (a region of large continuum uncertainty) systematic relative humidity errors must be kept to the order of 5% . This requirement is beyond the limits of most radiosondes used for operational humidity measurements.

Additionally, random or systematic temperature errors at or less than the 1K typical of radiosondes rarely lead to errors greater than 2% across the 400 to 1500 cm^{-1} region. Nevertheless, effects of temperature errors may be kept less than 1% by reducing the temperature error to about 0.3 K . As for the spectrally integrated longwave flux, the effects of systematic measurement errors is estimated to be 3.8 W/m^2 per Kelvin and 6.3 W/m^2 per 10% relative humidity. The effects of random error are about half of these. Thus the use of radiosondes, with typical

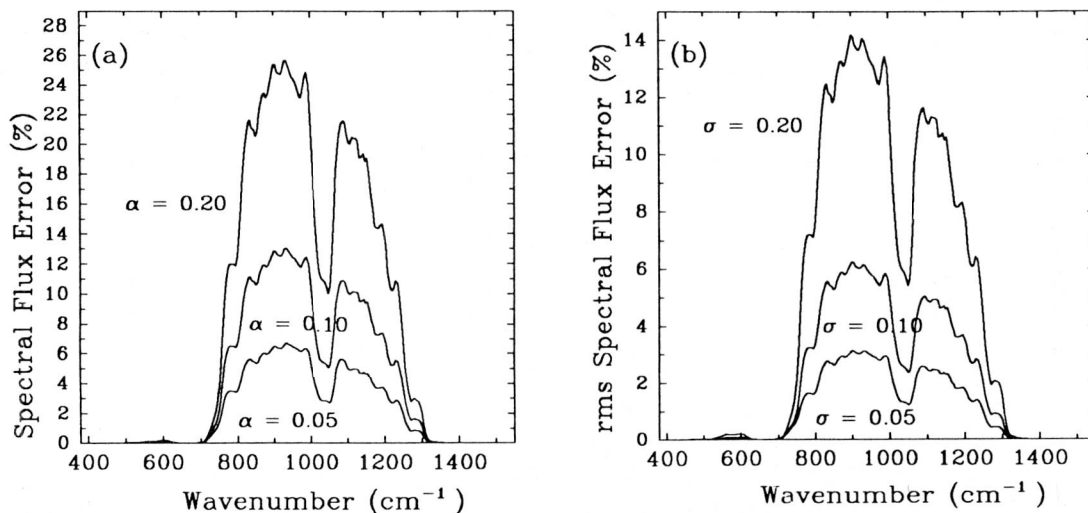

Figure 9. Spectral distribution of possible errors in calculated spectral flux (or intensity) due to systematic (a) and random (b) errors in the tropospheric water vapor distribution. Calculations were performed with LOWTRAN7 for the AFGL midlatitude summer atmosphere. Fractional systematic perturbations are denoted by α , and σ is the standard deviation of the assumed normally distributed error. The calculations were done every 5 cm^{-1} , although the LOWTRAN7 transmittances are averages over 20 cm^{-1} .

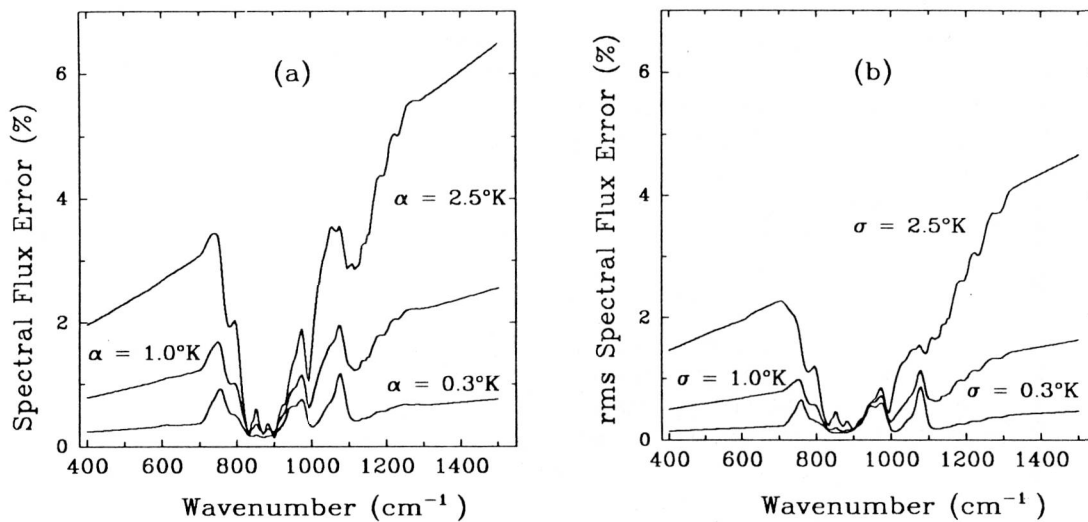

Figure 10. As in Figure 9 but for the temperature distribution. The perturbations (α) and standard deviations (σ) are given in Kelvins.

1K and 10% relative humidity errors, can lead to calculation errors that are climatically significant.

For cloudy conditions, the longwave calculations become additionally sensitive to uncertainties in the altitude of the cloud base, the fractional cloud cover, the cloud water content and the water phase. For the spectrally integrated flux, the flux increases by about 40 to 70 W/m² over the clear sky values (400 to 200 W/m²) as the sky become 100% overcast in the lower troposphere (depending upon the geographic location and cloud altitude). Because the flux is linear in the effective cloud fraction, the effective cloud fraction (including the geometric effects) errors must be kept to less than about 15% in order to keep the flux uncertainty to less than 10 W/m². Similarly, the cloud base must be known to 1km for a 5 to 10 W/m² uncertainty for 100% overcast conditions.

The spectral distributions of these uncertainties are expected to be of the same magnitude as the radiosonde errors. For solar radiation, the sensitivity of the direct transmittance to water vapor is expected to be of the same magnitude seen for longwave radiation. The effects of different cloud and aerosol properties will require extensive calculations prior to the start of field observations.

Site Selection Issues

To meet the basic ARM goal of providing data to allow valid global climate modeling, it is necessary that ARM have a site in every major climate zone of the globe. This is possible in practice

with a few permanent sites in well-chosen, climatically significant areas and a mobile site. The mobile site can test models at intermediate sites and also explore additional locations in new regions. Thus, one site selection criterion will be that the site represent some climatically important region, preferably one that experiences a wide range of meteorological conditions to assure that models cover all limits of their variables. Another criterion is that the site be both accessible to NASA satellite observation and that the surrounding region covering the area of an ERBE satellite nadir pixel (i.e., ≥ 30 km diameter) have uniform surface characteristics.

Other site selection criteria are more pragmatic. Sites must be logistically supportable ("there must be a road to it"), politically stable (preferably U.S. territory), and far enough removed from population centers to insulate the experiments from acoustic and electromagnetic interference, as well as insulate the local population from the same.

Clearly, judging the relative importance of each of the above criteria is not a simple matter. This important task will be accomplished in direct consultation with the Science Team.

Experimental Design

EXPERIMENTAL

DESIGN

Experimental Design

The ARM Program will measure the radiation field and study both radiation models and cloud parameterizations in GCMs. The measurement strategy and instrument selection will respond to the key scientific requirements. Specifically, the program will provide experimental and computational support for the detailed study of radiative physics and the generalization of those results to physical scales compatible with current and future generations of GCMs. To support these goals, the instrument selection must support:

- the measurement of key aspects of the radiation field under a range of climatologically significant meteorological conditions sufficient to constrain detailed radiative calculations
- detailed studies of atmospheric trace gas, aerosol, and water-vapor distributions
- detailed studies of meteorological variables, including cloud type and distribution, wind field, temperature, etc.
- measurement of large-scale vertical velocities
- measurement of critical microphysical properties of clouds.

To support these measurements, it will be necessary to have a support infrastructure with:

- near real-time processing of data and execution of models
- state-of-the-art calibration methods, including onsite calibration at facilities explicitly designed to support the measurement systems and redundant measurement suites providing near real-time evaluation of instrument performance.

The intent of the measurements is to test the predictive power of the models. Therefore instrumentation will be improved continuously. A specialized research instrument might be brought to an operational state and then added to the complement of instruments. Observing protocols

may also be changed to increase the quality of the tests. All critical measurements will be systematically replicated.

In this section of the plan, we describe the basic elements of the Clouds and Radiation Testbed (CART) shown in Figure 11. The description includes the physical design of an ARM site, its instrument complement, site selection, the data management strategy, and a brief discussion of some research needs that will support successful prosecution of the ARM Program.

The Basic Elements of the Measurement Program

The heart of ARM is a field experiment, which will be deployed in a series of settings chosen for their climatological significance. The goal of the observations is to allow a systematic exploration of the performance of radiation models under a wide range of meteorological conditions. The basic experimental design for ARM will incorporate the following elements:

1. four to six permanent base sites, which include a central facility and a network for three-dimensional meteorological mapping surrounding each base site
2. an in situ sampling program operated on a continuing basis
3. 16 to 25 extended observing stations distributed around the base site covering an area comparable to a GCM grid cell
4. a mobile ARM observing system
5. a series of specialized observing campaigns focused on the study of particular atmospheric properties and processes.

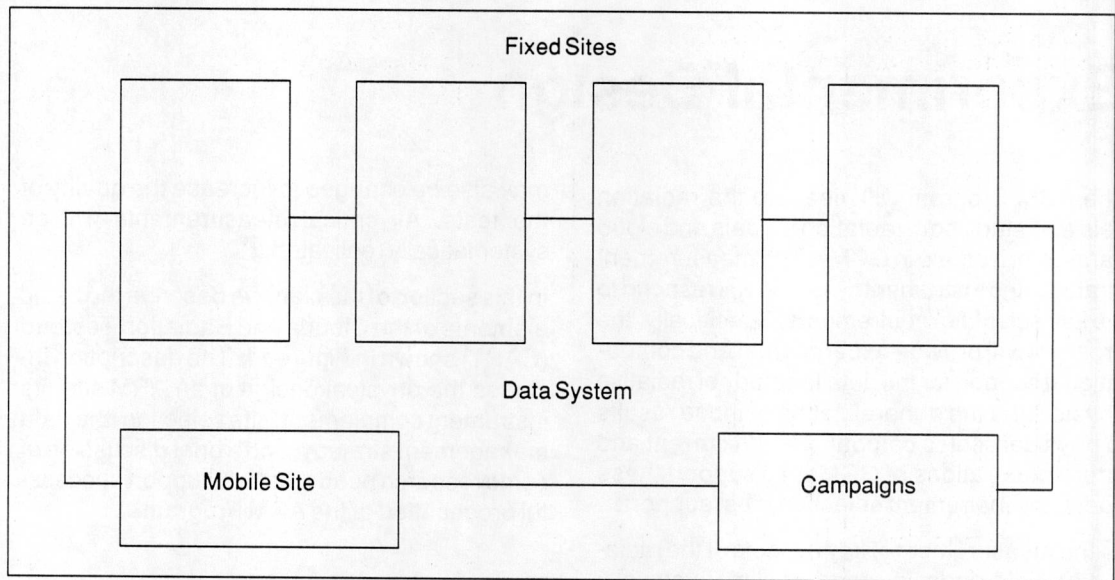

Figure 11. Clouds and Radiation Testbed (CART).

Base Sites: The Measurement of the Column

The base sites for ARM have two closely associated components, central concentration of instrumentation and support facilities and an extended network for three-dimensional mapping of meteorological variables.

The Central Facility

A major focus of ARM is the detailed verification of radiative transfer codes. This will occur through a comparison of measured and computed values of the radiation field. It is therefore necessary to make measurements of both the radiation field and the physical conditions that control the radiative transfer. ARM will field two classes of equipment at the base sites to support this activity. There will be equipment for measuring the radiation field directly and equipment intended to characterize the local radiative circumstances including surface and cloud properties. The base site instruments will include

more complicated pieces of equipment, some of which will be more experimental in nature. Figure 12 illustrates the conceptual design for the central facility.

The base site will contain the following classes of equipment. A detailed listing of these instruments is found in the Experimental Design Section of this document.

Radiometric instruments: A set of radiometric instruments capable of measuring the wavelength dependence of the irradiance with great detail; a set of radiation instruments that duplicate those at the extended network stations.

Meteorological instrumentation: A set of remote-sensing-based meteorological equipment for characterizing the atmospheric column above the base site; a set of meteorological instruments that duplicate those at the extended network stations.

The onsite calibration facility: A separate facility maintained for the repair and calibration of the instrumentation.

The data reduction and preliminary analysis facility: An onsite facility that will perform the first two levels of quality assurance on all data collected at the site; meteorological and radiometric data streams will be merged

on site; the data will then be made available to the science team to perform real or near-real time diagnostics of radiation codes and parameterizations.

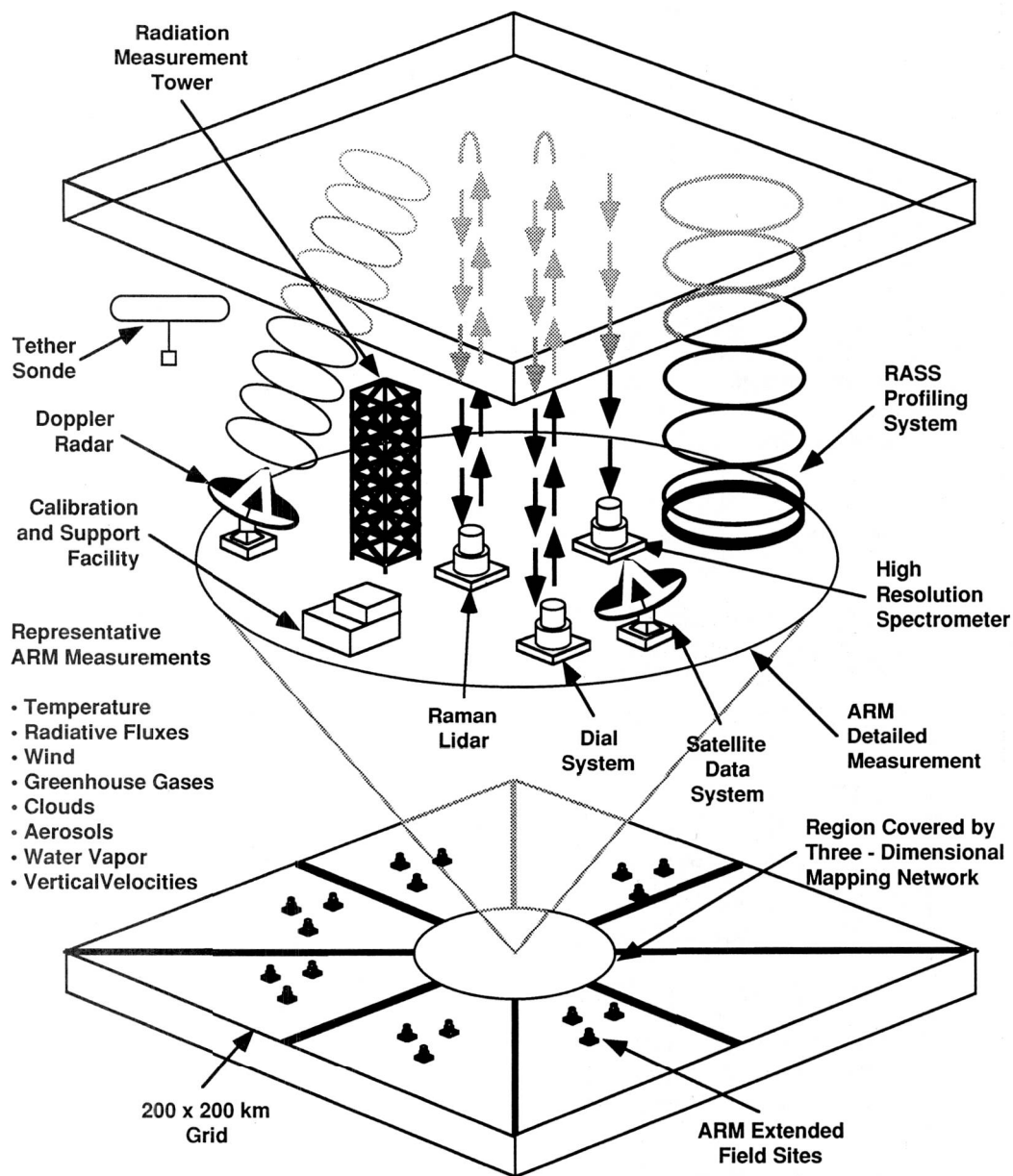

Figure 12. Conceptual design for the central facility of the ARM experimental network.

An additional important feature of the base site will be periodic satellite observations. These allow the ARM site to aid in calibration of the satellite and to extend ARM observations upward in altitude.

The Three-Dimensional Mapping Network

A series of auxiliary stations will surround the central facility within a 20-km radius (this radius was derived from consideration of the scale height of the atmosphere). These stations will contain instrumentation designed to measure the three-dimensional structure of the atmosphere near the base site and will make use of fundamental profiling equipment, as well as basic radiometric and meteorological equipment. A focus of the specialized stations will be the reconstruction of the cloud geometry surrounding the base site using state-of-the-art photogrammetric methods. This cloud "visualization

system" will be supplemented with a system of wind profilers capable of measuring large-scale vertical velocities. These observations are critical to the study of cloud parameterization and cloud formation and will provide three-dimensional meteorological information both synoptically and temporally.

In Situ Sampling Program

Figure 13 provides some indication of the complexity of the cloud microphysics problem and its importance to radiant transfer, and it is an idealized representation of the generation and metamorphosis of cloud and precipitation particles. Since all of these quantities will vary both horizontally and vertically over the ARM measurement regions, documentation of these features as a function of time and position, to the degree of detail needed by GCM modeling, is essential.

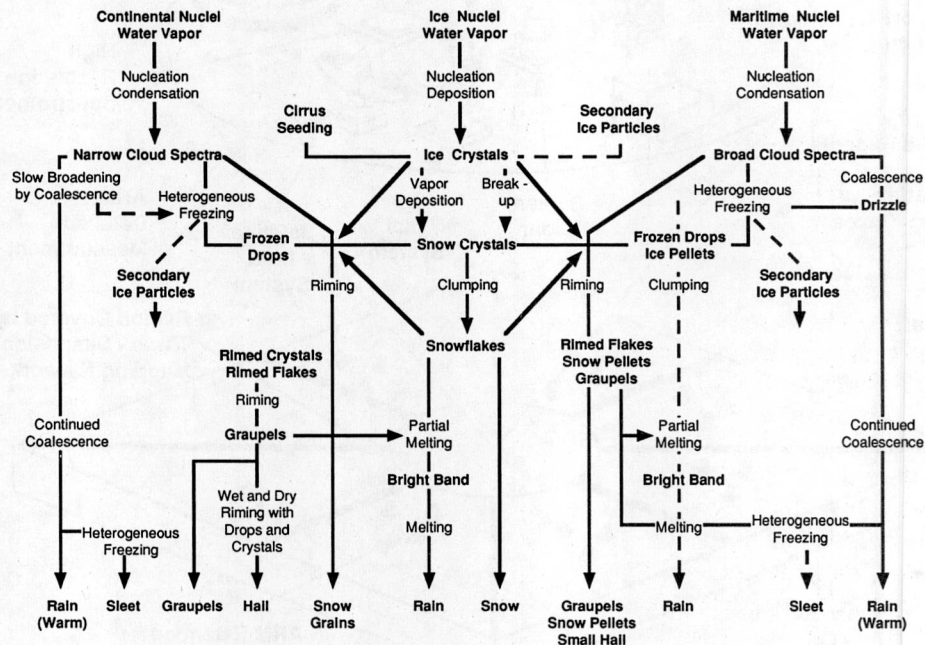

Figure 13. An idealized representation of the generation and metamorphosis of cloud and precipitation particles.

Remote sensing will provide continuous measurements of some microphysical variables. For example, the sum of the mean ice particle terminal velocity and the air velocity can be obtained using vertically pointing Doppler radar data. Subtraction of air vertical velocity determined by the wind profiler allows the ice particle terminal velocity, and thus ice particle size to be inferred. Millimeter-based radar, currently in the development stage, in conjunction with in situ calibrations, can be expected eventually to provide measurements of basic cloud microphysics. Lidar measurements will result in additional, but limited, information regarding water content of clouds.

Remote-sensing instruments, however, are by themselves inadequate for these purposes for two major reasons. First, many of the essential parameters (e.g. size distributions, ice crystal morphology) cannot be measured by these techniques, at least with present technology. Second, even for entities that can be measured remotely, these techniques depend strongly on ancillary point measurements and calibrations to establish "ground-truth." As a result of these considerations, quality aircraft cloud-physics measurements are essential for ARM.

Extended Observing Stations: Measuring the GCM Grid Cell

A principal goal of the ARM Program is to provide data that can improve the GCM parameterizations of clouds and their microphysical composition. The smallest domain explicitly represented in a GCM is the single grid cell. This cell is orders of magnitude larger than the scale of many important cloud characteristics. It is possible that over the next decade model resolution will increase substantially so that single grid cells will have dimensions of a few tens of kilometers. Even so, because clouds can have dimensions less than a kilometer, some subgrid parameterization will be necessary. In order to

test these crucial parameterizations, the ARM measurements must cover a larger extent than that of the central site alone.

Therefore, the ARM experimental design includes an array of 16 to 25 extended observing stations that will be placed throughout the area surrounding a major site. The extended observing area of a base site will include a region of roughly the same size as that currently expected for near future GCM grid cells (a 200 km square). The instrumentation at these stations will be less expensive, less specialized, and capable of more autonomous operation. The instruments at the extended stations will be designed to collect the basic radiometric information and conventional meteorological data needed to characterize the radiative transfer throughout the extended area. Only limited vertical information will be collected.

The extended observing stations will also provide the information needed to determine how temporal statistics calculated at the central site can be used to characterize spatial statistics calculated for the extended region. Also, spatial variations in the extended station measurements will be used to test model treatments of subgrid-scale surface variations. The ARM Program will provide data that will be useful in characterizing the statistics of cloud inhomogeneity and surface albedo on a subgrid scale.

Other parameterizations that affect radiation, such as atmospheric composition, temperature, and humidity, present fewer difficulties for modelers than clouds because their subgrid-scale variance is smaller. However, under unusual meteorological conditions, or when the surface within the grid cell is highly nonuniform, these parameters also have strong subgrid-scale horizontal gradients. Therefore, the extended ARM observing stations will provide measurements of radiation and meteorological variance, as well as cloud variance. These data will be a valuable aid in the development of accurate and appropriate parameterizations that account for relevant atmospheric variables.

A principal goal of the ARM program is to provide data that can improve the GCM parameterization of clouds and their microphysical composition.

The data from the network of extended stations will serve several other functions within the ARM Program, as well. Most importantly, the extended stations will provide data for the intercomparison of satellite radiometric observations (i.e., operational and research satellites). To facilitate this role, the extended network geometry will include the typical 10- to 30-km diameter footprint of a satellite's narrow radiometric field of view. In this way, ARM will provide the opportunity for "ground truth" of a satellite's observations, for comparison of the radiation fields measured by satellite with the ARM results, and for extension of ARM measurements to higher altitudes. This second activity will indirectly advance the overall ARM Program goal of obtaining an accurate radiometric "figure of merit" for GCMs.

The extended network will provide critical data for the study of cloud formation. This topic is central to both the improved parameterization of clouds and the correct modeling of overall cloud systems in GCMs. The genesis and development of clouds can only be understood with some knowledge of the upstream radiative and meteorological conditions that influence the cloud conditions at a later time within the central measurement region. Data taken 100 km upstream can provide critical information on the preconditions of the atmospheric parcels that are advected to become clouds in the central region some hours later.

Time averages of measurements made at the central ARM site can give some indication of the variation of those quantities within the region. However, under nonstationary weather conditions, a time average does not give the same measure of regional characteristics as does an "instantaneous" spatial average. This is particularly true for the large regions that must be included in GCM comparisons. Time averaging tends to provide a representation only for the regions upwind and downwind of the central site. It is necessary to have not only average values but also measurements of the spatial variation or dispersion of radiometric and meteorological quantities.

Based on the above considerations, the extended measurement network has been included as an integral element of the ARM experiment. Data which it will provide are critical to the success of the program objectives. The extended network will assure a high level of confidence in the radiometric figure of merit, indicate difficulties and improvements for GCM subgrid parameterization, and provide a measure of the grid resolution required for modeling accuracy.

Mobile ARM Observing System

The use of a mobile version of the basic ARM observing system in directed campaign studies will be central to many of the program goals. The ARM Program incorporates several different approaches to campaign planning. The first approach employed will be through short-term operations aimed at the exploration of specific mechanisms and processes. This activity will lead to longer-term operation and data acquisition designed to reveal experimental anomalies at the base sites. Finally, campaign operations will be used as a means to verify models for conditions intermediate to those of the base sites.

Many of the campaign operations will make use of a mobile observing system. This system will include mobile instrumentation, similar to the NOAA lidar mobile unit shown in Figure 14, to implement the critical ARM measurements taken at the fixed sites. The short-term campaign operations will field this mobile system for a period from a month to a year at selected sites. Longer-term studies may span a period of years. In all cases, the mobile instrumentation will be deployed with specific scientific hypotheses in mind.

Initial, short-term field campaigns will be conducted in relatively well-defined environmental systems. In this way, it will be possible to further isolate specific radiative processes and mechanisms. For example, a campaign study in a large

The use of a mobile version of the ARM observing system in directed campaigns will be central to many of the Program goals.

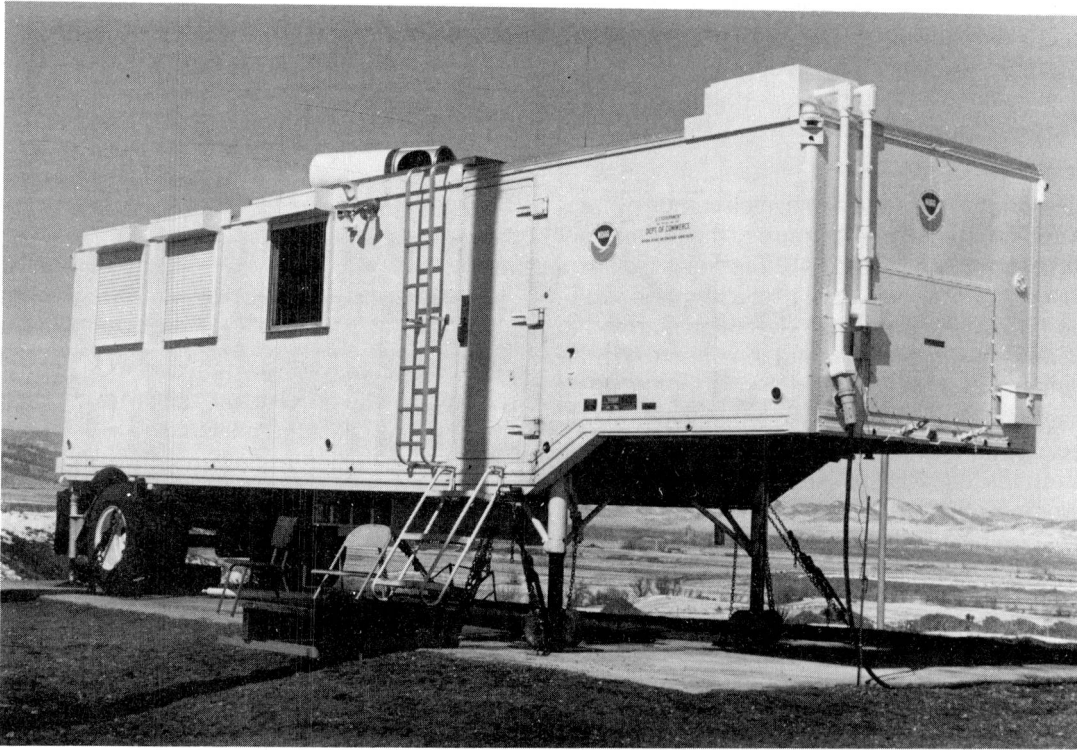

Figure 14. The NOAA mobile lidar unit.

desert environment would allow for clear-sky continental conditions to be evaluated with minimal soil moisture, cloud influence, and biospheric feedback. Ocean and ice-covered sites are also favorable locations for this class of campaigns. Field studies in such remote areas would be minimally impacted by local or regional air pollution. Such "pristine" data would allow current parameterizations to be tested in the simplest model scenario.

These initial field operations would lead naturally to other short-term studies of more complicated biospheres or pollution impacts. These would evaluate more subtle radiative balance issues. One proposed campaign would test the influence of cloud condensation nuclei (CCN) levels on cloud type, lifetime, and scattering properties. Another would focus on the effect of

changing tropospheric chemistry on regional scale meteorology and climate. These field efforts will be integrated closely with the model development activities. They will support the short-term testing and improvement of specific GCM problem areas that become apparent as preliminary ARM results are gathered.

ARM will also encounter a variety of circumstances in which it will be desirable to supplement the routine data at a fixed site with measurements from additional instruments. Equipment may be deployed at the ARM site for a finite time in order to study a particular atmospheric process not covered by the permanent measurement suite. Such measurement campaigns would also allow the opportunity to take advantage of an extraordinary climate condition. The campaign instruments are not likely to be operational in the

same sense as the permanent, fixed-site instruments. Rather, they will be specialized equipment which are not necessary, or not practical, to operate on a continual basis, but which provide data necessary for a directed campaign investigation.

The longer-term data acquisition campaigns will be conducted at one or more of the permanent ARM sites. These studies will serve as the basis for continued experimental reliability and evolution. Onsite campaigns have been planned to conduct the rigorous calibration of instrumentation needed to support the stringent ARM accuracy requirements. An ongoing campaign activity will be the testing and calibration of novel methods for conducting the ARM remote measurements. In this way, long-term campaigns will enable ARM to remain at the state of the art in measurement technology as the experiment progresses.

Extended campaign operations can also serve to diversify the overall data base through data-collection with the mobile observing system. The mobile system may be deployed at a site which represents a climate type not covered by the permanent ARM sites. Such a campaign would serve to conclusively test the predictive ability of a model to reproduce the observed radiation profiles.

There would be no way models could be "tuned" to conditions at a previously unexamined evaluation site. For this reason, these studies would also serve to highlight any unforeseen anomalies in ARM data from the fixed sites.

Thus, the ARM mobile observing system and campaign activities will respond to the program's need to diversify and expand data sets and address specific scientific questions which arise as the experiment progresses. This campaign capability of ARM is likely to become even more crucial as the program begins to gather specific results and approach its goals for model improvement. The mobile system will be especially valuable for the fine tuning of parameterization theories.

Proposed Experimental Technologies: The Technological Response to the Requirements

The usefulness of ARM data depends upon the ability to make precise and accurate measurements of the critical quantities. The development of a full collection of new instruments for this purpose would require significant lead time. It would also preclude the acquisition of significant data on the time scale (5 to 10 years) over which the project hopes to make a contribution to the modeling of climate change.

Therefore, ARM will depend heavily on the early deployment of existing research quality technologies which are currently in use and available. These instruments will then be supplemented and improved over the course of the experiment. It is expected that the natural evolution of technology and experience garnered from ARM itself will motivate general improvement in the observing system. This approach to the deployment of ARM is especially attractive since the measurement technologies developed over the past decade have now reached levels of accuracy adequate for the initial deployment.

This section of the document describes the technologies which have been judged most promising for obtaining the critical measurements. The instrument selection reflects the observing philosophy discussed in the Requirements Section. ARM will rely heavily on multiple measurements to provide a cross-check and verification process for both the equipment and the data. Therefore, the instrument suite will include several complementary approaches to gathering the same experimental quantity. For

*The usefulness
of ARM data
depends upon
the ability to
make precise
and accurate
measurements
of the critical
quantities.*

the radiometric instruments this results in overlapping wavelength coverage. In the meteorological instrumentation it results in a mixture of complementary remote sensing instruments and direct sampling sounding systems.

The following material is divided into three sections that cover the major elements of the observing program: the base site, the extended observing system, and the calibration facility. Each section contains a discussion of the selected instrument complement associated with that element. The sections will also address relevant deployment issues for the varied equipment. A background discussion of the technologies employed by ARM can be found in Appendix B for those who may be unfamiliar with some of this equipment. The appendix includes a description of the state of the art of radiometric and remote sensing based meteorological measurement systems. There is also a brief discussion of surface property measurements.

In several cases reference is made to instruments that are not yet ready to be deployed as part of the initial ARM field experiment. This includes: currently developing technologies that may soon be available for use; rapidly changing technologies that are likely to develop improved instruments; and experimental technologies that will not be practical for some time. Some of these instruments and recommendations concerning their development are contained in this section of the report. However, any instrument development through the program will be an enhancement rather than a necessary pre-condition. Existing technology is fully adequate to allow prompt and effective fielding of ARM.

The Base Site Instrumentation

One of the major objectives of ARM is the detailed observational verification of radiative transfer codes through simultaneous measurement and computation of critical components of

radiative transfer. In order to support this activity it is necessary to not only make measurements of the radiation field but also of the physical conditions that control the radiative transfer. As such, there will be two classes of instrumentation at the heavily instrumented base sites, those for measuring the radiation field and those intended to characterize the local radiative circumstances. Instruments measuring the radiation field may produce either spectrally resolved or broad-band data.

Spectral Radiation Instrumentation

As discussed in the Requirements Section, the spectral characteristics of the radiation field are necessary to properly identify the various radiative transfer effects necessary to predict global climate. Therefore, this portion of the instrument complement is critical to the success of ARM. As a result, the instrument complement selection emphasizes redundant measurements and varied observing strategies.

In the longwave regime, four spectrometers have been selected. These include two interferometers, a grating spectrometer for measuring atmospheric emission and a much higher resolution interferometer for measuring the solar infrared spectrum. The spectrometers that have been identified for ARM were selected from a longer list of candidates by requiring the following characteristics:

1. coverage of as much of the wavelength range 3 to 25 μm as possible (beyond 25 μm the atmosphere is almost completely opaque due to the water vapor rotation bands)
2. high spectral resolution (1 cm^{-1} or better)
3. internal blackbody calibration (at least one temperature)
4. suitability for absolute emission measurements
5. field-proven and rugged design.

The specific list of instruments is shown in Table 1. These type of spectrometers have been extensively field tested and thoroughly presented in the literature (e.g. Kunde et al. 1987; Brasunas et al. 1988; Murcray et al. 1984; Murcray 1984; Revercomb et al. 1988).

In the visible region, a spectrophotometer will be used for the spectrally resolved observations. If a rotating shadowband spectrometer can be field proven, it will be included in the instrument complement. An automated filter photometer will also be employed to provide a moderate resolution measurement comparable to that obtained using hand held sunphotometers.

Table 1. The spectrophotometric recommendations for ARM.

| Instrument | Spectral Range | Resolution |
|----------------------|--------------------|------------------------|
| Interferometer #1 | 5-15 μm | 0.02 cm^{-1} |
| Interferometer #2 | 4-16 μm | 0.3 cm^{-1} |
| Solar Interferometer | 2-20 μm | 0.002 cm^{-1} |
| Grating Spectrometer | 8-25 μm | 0.5 cm^{-1} |

Broad-Band Radiation Instrumentation

The strategy for the broad-band instrumentation is to duplicate, to the extent possible, the instrumentation selected by the World Climate Research Program (WCRP) for the Global Baseline Surface Radiation Network (GBSRN). The instrumentation deployed at the base station will provide redundancy, to support calibration and to facilitate quality control. The discussion of radiometric instrumentation at the extended stations (included below) describes the currently contemplated complement of instruments.

Meteorological Instrumentation

Measurement of the meteorological conditions associated with radiative transfer is one of the principal tasks of ARM. Previous radiation studies have had to rely upon radiosonde or aircraft measurements of temperature, humidity, cloud and aerosol profiles. However, the atmosphere is sufficiently dynamic that such profiles are rarely useful for studies of radiative processes. Radiation properties change with the instantaneous state of the atmosphere. Radiosondes and in situ aircraft sensors measure profiles which are time-lagged by up to 30 min and follow a curved path in three-dimensional space. Such instruments are necessary to gain access to data and regions inaccessible to remote measurement, and for calibration, but these profiles are not coincident with the radiation observations either in time or space.

Rapid atmospheric structure variation is an especially difficult restriction for the measurement of atmospheric humidity, which is now known to vary on small scales. Melfi et al. (1989) have examined measurements from the Raman lidar in detail for warm and cold frontal passages and a calm high-pressure situation. Even a calm night exhibited significant turbulent moisture variation. They observed step discontinuities in the moisture profile, which changed on time scales of a few minutes or spatial variation on the scale of a few hundred meters. This is consistent with earlier studies by Browell et al. (1984) who observed the variability of water vapor in the troposphere using Differential Absorption Lidar (DIAL) from an airborne platform. These results illustrate conclusively that moisture "profiles" returned by radiosondes will generally bear only a gross resemblance to the instantaneous profiles directly overhead.

Fortunately, advances in surface profiling technology during the past decade have produced modern instruments capable of near-instantaneous measurement of vertical profiles.

These are generally possible for important variables to altitudes of at least 5 km. In some cases, profiles to 10 km or more may be measured. Of these new profiling technologies, ARM has chosen to field those which have been field-proven and that give the best possible vertical resolution and accuracy. The instruments that best meet these requirements are Raman lidar and DIAL (Melfi and Whiteman 1985; Melfi et al. 1989; Ismail and Browell 1989) and the Radio Acoustic Sounding System, or RASS (May et al. 1988). Both rely on sound physical principles. The combination of these two technologies will provide the fundamental measurements of temperature and humidity profiles with accuracy exceeding that of radiosondes. Microwave profiling systems give considerably poorer vertical resolution than Raman lidar and RASS, but would add a desirable degree of redundancy.

The proposed complement of profiling systems is as follows:

Raman Lidar and DIAL: These technologies will be used to measure **water vapor profiles**. Currently, the Raman lidar has its best operation at night, when it can cover the region from 300 m to 7 km every 2 min. Integration times are of the order of 30 min when sounding the region from 7 km to the tropopause. The daytime Raman system is expected to operate up to 6 km. The vertical resolution of the Raman systems is of the order of 150 m, and the error is typically 0.1 to 0.2 g/kg or 5%, whichever is less. The Raman lidar has consistently proven capable of providing hours of reliable field operation. The associated instrument and data systems have never had problems resulting in more than a few minutes of data loss, which is exceptionally reliable performance. The DIAL technology has similar ranging and error characteristics, although it is less well developed for operational use than the Raman lidar.

RASS: The RASS provides good measurement of **virtual temperature**. It is also possible to get **actual temperature** by combining RASS data with humidity data from Raman lidar. ARM plans

to field a 400 MHz system with a 300 m to 3 km altitude range and a 50 MHz system with a 2 to 7 km range. The vertical resolution of these systems is 150 meters, with an accuracy better than 0.5°C when the vertical wind component is below 0.25 m/sec. Otherwise the system accuracy is 1°C. The RASS will also be used in a wind profiling mode to obtain measurements of **wind field and turbulence** information with the same vertical resolution.

Lidar: The Wave Propagation Laboratory (WPL) of NOAA and NASA Langley have developed a wide variety of lidar systems for **aerosol and cloud measurements**. The details of these systems are discussed in Appendix B. The selection of specific lidar instrumentation will be conducted upon analysis of WPL's CLARET results (see Management Plan Section). At present it is clear that a 10 micrometer CO₂ lidar appears highly desirable. Measurements from this instrument will eliminate the need to extrapolate aerosol properties from those obtained at visible wavelengths used by most lidars.

Tethersonde and tower system: These will provide for **pressure, temperature, humidity, and ozone** measurements up to 2 km. Remote sensing systems are "blind" to the region just above the surface. Most of the radiation in the more opaque spectral bands will be coming from this blind region. Tower- and sonde-based measurements will be invaluable for filling this data gap and for providing calibration points for the Raman lidar and RASS.

Dobson instrument: Ozone measurements from this instrument (supplemented by occasional ozonesonde launches) are highly desirable, but may not be possible. Tropospheric ozone can be very important in estimating the infrared flux in the 9.6 micron region of the spectrum.

Satellite data: Since profiling accuracy declines with altitude, satellite retrievals of temperature, humidity, and ozone will be relied on for information above the mid-troposphere.

Three-Dimensional Mapping Instruments

There are no well-established systems for mapping the three-dimensional structure of the atmosphere in a reasonably automated fashion. Appendix B has a discussion of a recent review of the history of these systems. As described later in the Experimental Design Section and the Management Plan, an important part of ARM will be an equipment development activity. The CLARET experience at the WPL may provide some guidance for the development of this system.

The requirement to provide some form of cloud "visualization" system for mapping cloud extent and cloud typing could be met with a system based on imaging arrays of devices like charge-coupled devices (CCDs). A system of this type offers far more automatic data processing options and should be able to take advantage of the many years of development of advanced photogrammetric techniques that have been applied to aircraft and satellite imagery. Finally, the requirement for mapping the three-dimensional velocity field could be met with a system of wind profilers.

Additional Equipment

In addition to the radiation and related meteorological measurements which are the focus of ARM, a variety of other measurements will be taken to assure a complete data set. Some of the additional equipment provisions necessary for these are described here.

Trace gas concentrations: These will be determined from flask samples and direct real-time sampling using commercial nondispersive infrared analyzers. The solar spectrometer data can be used to infer trace-gas column amounts.

Surface aerosol concentration: Knollenberg counters, or equivalent, can provide the aerosol data needed to impose an important boundary condition on the aerosol profile. Aerosol lidars, like other profiling systems, have a blind region near the surface.

Aerosol optical depth and water vapor column amount: There are a variety of methods which will be used to infer these important column densities. One risk associated with these methods, which include sunphotometers and radiometers, is that they rely on knowledge of radiative transfer for calibration and interpretation. Nevertheless, despite the question as to whether these are quantities that should be inputs to the radiative models or predicted by them, the measurements will have very useful corroborative value.

Routine surface weather observations: It is particularly crucial to have routine data of surface pressure to calibrate the satellite data, which are expressed in pressure coordinates. The central site will duplicate the basic meteorological information available at the extended observing sites, adding appropriate other measurements as required.

Considerations for Deployment of the ARM Sites

There are definite site restrictions and needs associated with the chosen base site instrument complement. The most restrictive of these is the need for a large flat area, without significant obstructions for at least 1 km in every direction, for installation of the RASS antenna arrays. The antenna site must be cleared and free of obstructions like tree stumps; bulldozer grading may be required. The location of the RASS must also be remote from populated areas because of noise from the acoustic sources used in the technique.

Extended Observing Station Instrumentation

The extended station instruments are intended to be less expensive than the base site equipment. They must also be capable of more autonomous operation. The primary mission of these instruments will be to collect basic radiometric information and conventional

meteorological data. There will be only limited vertical information collected.

The ARM selection of extended station instrumentation is motivated by the desire to make the instrument complement as compatible as possible with that of the GBSRN, a program being designed by John DeLuisi of NOAA for WCRP. The ARM Program will attempt to coordinate its final instrument selection with GBSRN by matching their choice of specific instruments to the greatest extent possible. The only exception is that a rotating shadowband radiometer may be added or substituted for the sunphotometer, pending comparison operation and calibration studies. The basic measurements and instrumentation for the extended sites are listed below. Many of the instruments, and the problems associated with their calibration, are described in more detail in Appendix B.

Radiometric measurements instrumentation will be:

- pyranometers and tracking pyrhemometers (several of each, some unfiltered and some filtered)
- pyrgeometer and low-resolution thermal infrared radiometer to cover both sides of the 9.6 μm ozone band (latter provides direct monitoring in the atmospheric "window" regions)
- upward and downward components of solar and longwave infrared (includes longwave net radiometer)
- rotating shadowband radiometer for flux ratios (rotating shadowband spectrometer would be preferred and will be substituted for some of the radiometers if development is successful)
- spectral ultraviolet at some sites.

Other instrumentation at the extended sites will be:

- normal complement of instruments for weather station measurements such as surface temperature, relative humidity, winds, etc.

- micrometeorological instrumentation for measuring the ratio of latent to sensible heat fluxes
- all-sky camera. This instrumentation is being investigated for inclusion in the GBSRN. Some of the issues associated with all-sky mapping are mentioned above with respect to the base site operation and in Appendix B. Automatic measurements of cloud amount are very desirable, particularly for coordination with satellite observations.
- lidar for measuring cloud ceiling at the site.

Other measurements to be conducted in conjunction with the operation of the network will be:

- routine measurement of surface reflectivity surrounding the sites.
- regular soil moisture sampling.

Aircraft-Borne Operational and Campaign Measurements

In addition to the complement of instruments that will be permanently placed at the base and extended sites, the ARM research program will require additional instruments which will be used on a campaign basis. Important ongoing campaign activity at the fixed sites will be the routine overflight of airborne sensors for measuring cloud microphysical properties. As has been described previously, these data will be central to the ARM mission.

The aircraft-cloud microphysics measurements of ARM can be subdivided into two types: primary and secondary. Primary measurements are those that pertain to cloud-physics features that directly influence radiative transfer. Secondary variables are those quantities that directly influence the primary features but influence radiative transfer only indirectly. ARM will concentrate on the primary cloud-microphysics measurements, and will perform selected secondary measurements as necessary. Key

primary and secondary measurements are summarized in Table 2. Some brief comments regarding the measurement systems listed in Table 2 are provided in Appendix B.

Calibration

Radiometric Calibration

The quality of the calibration procedures that will be applied to the network is critical for assuring the credibility of the network data. Poor calibration procedures will increase the magnitude of the data errors and reduce both the significance of any trends seen in the data or the

quality of any test of radiative models. The calibration procedures would be dedicated to maintaining rigid standards, rigorous application, and impeccable reference standards. Without this dedication, the objectives of the program will be compromised.

To support the required delicate care and calibration of the remote sensing instruments, each of the base sites will have a calibration facility to attend the needs of the base site and some portion of the extended sites. An example of such a facility is shown in Figure 15. In addition, there will be field calibration of the remote sensing instruments using radiosondes

Table 2. Aircraft-based measurement systems.

Part I: Primary Measurements

Quantity Measured

liquid water content
 solid water content
 cloud-droplet size distribution
 raindrop size distribution
 ice morphology and size distribution

Candidate Techniques

heated wire, integrated size spectrum (see below), virtual impactor (see Part II, below)
 integrated size spectrum (see below), virtual impactor (see Part II, below)
 optical probe
 optical probe
 optical array probe, Formvar replicator, foil impactor

*Part II: Secondary Measurements**

Quantity Measured

thermodynamic properties: temperature, pressure, humidity (1)
 aerosol loading and size distribution (2)
 cloud condensation nucleus count (3)
 ice nucleus count (4)
 aerosol chemical content (3)
 cloud-water chemical content (3)

Candidate Techniques

standard research aircraft package: resistance thermometer, piezoelectric transducer, mirror hygrometer
 optical probe, optical particle counter, electrostatic mobility analyzer
 controlled humidity chamber-optical counting device
 controlled supercooled chamber device
 low-pressure impactor
 counterflow virtual impactor

*Flagging convention for secondary measurements is as follows: (1) important and easy to perform; (2) important but moderately difficult or expensive to perform well; (3) important but very difficult to perform well; (4) relatively unimportant. Categories (1) and (2) are recommended for routine application; category (3) is recommended for intensive campaigns, as deemed advisable to specific campaign objectives.

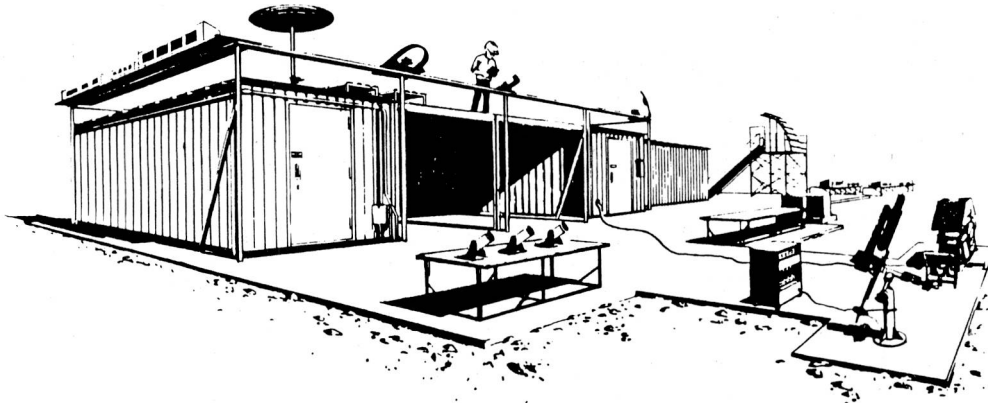

Figure 15. An artist's conception of the radiometric calibration facility at the Solar Energy Research Institute (SERI).

and other direct sampling techniques. Still further calibration can be provided through parallel operation of the mobile field station and any of the other base stations.

To assure homogeneity among the network measurements, all instruments will be characterized through a standard procedure. It is now quite feasible to characterize all pyranometric and pyr heliometric instrumentation with an active cavity radiometer that has been referenced to the World Radiation Reference (WRR) instruments kept at the World Radiation Center in Davos, Switzerland. Well maintained cavity radiometers are usually stable to within 0.3%, which is a tremendous advantage for maintaining standards at a calibration facility.

The characterization of the individual angular and temperature response functions of pyranometers is an example of the type of calibration issues that will be faced by ARM. The careful characterization of the response for each pyranometer is necessary for accurate measurements of short-wave flux. This requires calibration using a tracking radiometer (similar to Figure 16) to measure the direct-beam component, along with a well-characterized, shaded pyranometer for measuring the diffuse component. This technique is called the component-summation method. The method is applied on selected clear days to determine a pyranometer's so-called calibration constant over a range of solar elevation and azimuthal angles.

Commercially available pyranometers are fairly rugged instruments that are designed for a wide range of outdoor conditions. However, before they are deployed in the field, they need to have the above mentioned calibration and characterization performed. They can also be modified to allow measurement of the temperature of their sensor enclosure. These temperature data, along with a known temperature response function, can be used to ensure maximum accuracy. Once deployed in the field, the outer glass domes of a typical pyranometer must be cleaned daily to minimize the effects of dust, dew, frost, etc.

It is important to have a blackbody calibration source on site for calibration of all the spectrometers in the field, both before and after an observing period. It will be necessary to build a source with an emissivity at least 0.99 in order to match the 1% accuracy goal of ARM.

While radiometric calibration is an important issue, the proper calibration of the meteorological information is important as well. Measured profiles must be accurate enough that the predictions of spectral radiance are as accurate as the spectrometer measurements. Profiles will be available at least every 2 minutes from both the RASS and Raman lidar, and it is possible to time-average the profiles when the atmosphere is relatively stationary in order to reduce random error.

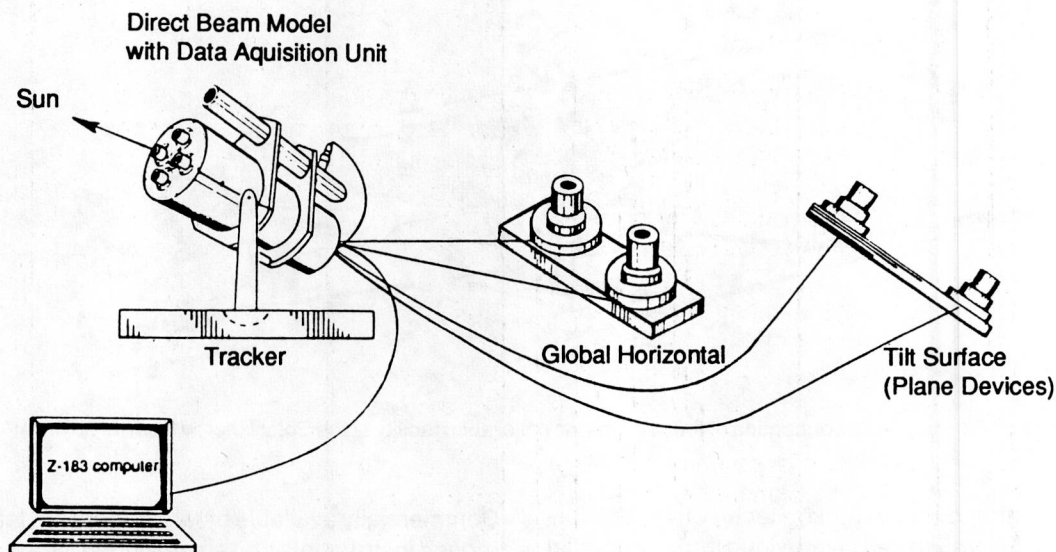

Figure 16. The calibration of radiometric instruments often involves the intercomparison of different kinds of sensors using the sun as the calibration source. A fairly common method of calibration involves the use of a tracking radiometer. The system shown here is in use at SERI.

Calibration of Profiling Systems

The calibration of the profiling instrumentation will have two basic elements. There will be a regular program of sonde releases whose instantaneous in situ measurements can be compared directly with the remotely sensed instruments. Some of this intercomparison with in situ sampling will be done on an extensive campaign basis. This is particularly true as cloud water- and droplet-size distributions are measured with remote sensing systems. Next there will be several measurements made of the same variables using different techniques. These cross-calibration approaches figure prominently in the quality control scheme that will be part of the data management system.

Role of Satellites in Calibration

Finally, there will be the intercomparison with satellite profiling systems. These intercomparisons will be quite interesting from the standpoint

of calibrating both the ARM data and the satellite data. The base station data, including both the meteorological data and the radiation measurements can be compared directly with corresponding predictions from satellites. The data can also be used as ground truth in support of satellite observations.

It is important to note that the precision and accuracy of satellite observations are controlled by the quality of both the data reduction algorithm and the calibration data sets. ARM has been designed to give fundamental data on those parts of radiative theory that are not only important to climate models but that are used every day in the analysis of data taken from space. In particular, radiometric measurements of the Earth's surface need to be corrected for radiative effects in the Earth's atmosphere. Both the ARM observations and the consequent improvements in theory will have a direct impact on the ability of satellite experiments to make long-term quantitative studies of global change.

Site Selection

The selection of the experimental sites is one of the most important activities in the ARM Program. Preliminary discussions have isolated five key selection criteria which will be used to evaluate the desirability and suitability of possible ARM sites. The discussion presented here is three fold. First, it covers the five site-selection criteria that have been identified thus far. Next, it addresses the issue of the number of sites required for success of the project. Finally, it applies the selection criteria to several of the most important classes of potential ARM sites. These are the initial considerations which have been dealt with in the planning of ARM. As outlined in the schedule in the Management Plan Section, the first ARM site will not be occupied for a year after the start of the program. During this interim, the final site selections will be made on the basis of major input and guidance from the Science Team.

Site Selection Considerations

The site-selection process for ARM will be complicated. The final choices must incorporate the optimal combination of characteristics in several areas. The general groupings of the criteria are: climatic significance, climatic sampling, potential for synergism with other programs, scientific viability, and logistical viability.

The first three criteria will determine the desirability of a potential ARM site with regard to its ability to address the scientific objectives of the program. The fourth and fifth criteria determine the practicality of conducting the ARM experiment at a particular site. These two will comprise the final, limiting conditions on the selection of a site that has been determined to be scientifically desirable.

Climatic Significance

Climatic significance is the first criterion which a potential ARM site must satisfy in order to receive further consideration. A site may be considered climatically significant if it possesses radiatively important characteristics, is geographically prevalent, or experiences a wide range of weather and climate conditions. By this standard, an ocean site is the most obviously significant surface for study. Desert, ice, and tropical surfaces would also be considered significant. A potential site might also be significant because of its unique climatological conditions. For example, a site with consistent wind or cloud characteristics would be helpful for isolating specific climatic responses and behavior. A highly variable site might be important for observing the wide range of weather conditions necessary for characterization of the full scope of climate model parameters. A mid-latitude site that experiences four distinct seasons would be useful in this respect. Also, high-latitude sites and mid-latitude, mid-continental sites are predicted to be particularly sensitive to climate change, and therefore of particular interest.

This criterion excludes climatically isolated or idiosyncratic areas from consideration as initial ARM sites. For example, the Los Angeles basin would not be an appropriate choice. However, such areas may prove to be extremely interesting for campaign studies or for fine-tuning specific aspects of the radiation codes as the program evolves.

Climate Sampling

As has been described, the experimental characterization of a wide variety of climate conditions is crucial to the success of the ARM Initiative. It would be impossible to accomplish this with a single ARM site, even if it were located in the most variable climate available. Therefore, multiple sites will be necessary.

The primary criterion for choosing the suite of sites is to gain a representative sampling of the range of climate conditions. Obviously, two similar ocean sites or two desert sites would not be appropriate. The sites must be chosen to give complementary data sets that will contribute to a coherent overall database.

The apparent qualities of a site, such as topography and surface cover, are not the only ones that must be taken into account in choosing complementary sites. The less obvious, but radiatively critical, characteristics of cloud type, distribution, and migration, rainfall patterns, and aerosol loading are equally important. Another important variable involves the wetness or dryness of sites and the consequent effect on the ratio of latent to sensible heat. Careful consideration must be given to all these conditions to insure the usefulness of the sites in measuring the many subtle parameters of the radiation budget.

Synergism with other Programs

A degree of flexibility with regard to the siting of the ARM experiments allows the opportunity to coordinate the ARM data sets with those of other previous or ongoing field experiments. For example, it may be possible to co-locate an ARM site in a way that optimizes the utilization of the ERBE or EOS satellites, co-located at the location of the ISLSCP experiments, or in an area where a historical meteorological data set exists.

Such possible collaborations are, in fact, being investigated vigorously and are a fundamental consideration in the fielding of the ARM sites. The ARM Program offers the scientific community the opportunity to link a number of previously uncorrelated data sets into a coherent network. The ARM Program will make every effort in its siting decisions to provide the greatest possible synergistic benefit to all experimental groups concerned with climate change and atmospheric science.

Scientific Viability

The criterion of scientific viability determines the ability to make accurate, useable, consistent measurements at a site with the existing technology. Most importantly, the site must be radiatively homogeneous. This is necessary in order to measure the radiative characteristics of the site on the scale of a GCM grid cell. It also implies uniform topography and surface cover. An ocean site is ideal with respect to this criterion.

A more specific site requirement would be the availability of a large, flat area, without significant obstructions for at least 1 km in every direction, for installation of the RASS antenna arrays. This technology is vital for obtaining fundamental temperature and humidity profiles and is the major limiting equipment with regard to siting. A cleared area is also necessary for uninterrupted operation of tethered data collection.

Logistical Viability

The final criterion is that it must be logistically feasible to conduct the ARM experiment at the chosen sites. If the nature of the site or its logistics support make it difficult or impossible to make key meteorological measurements, then there is obviously no point in instrumenting the site.

Fundamental facilities and provisions must be available. A navigable road is the minimum requirement for transportation of equipment, staff, and building supplies to the site. Access to power and communications capability must be available for the operation of machinery, sensors, and data systems. Normal 110 V power must be available for all instruments, as well as a portable diesel generator furnishing 110 V power for mobile operations. With regard to practical considerations, an ocean site may be the least feasible.

The primary criterion for choosing the suite of sites is to gain a representative sampling of the range of climate conditions.

The ARM sites must be remote from populated areas because the acoustic sources used in the RASS technique pose possible discomfort and danger to the public and electromagnetic noise from populous areas may interfere with measurements. As the measurements and equipment for ARM are finalized, all such specific requirements must be accounted for in the siting considerations.

The site must also be situated in an area that is free of political or regulatory restrictions. This requirement may limit ARM to areas in U.S. possessions and allies. It also requires that the site be removed from air-flight paths, since a tower and sondes would interfere with commercial operations. Federal and state restrictions and regulations remove some sites from consideration.

Rationale for Multiple ARM Sites

The purpose of ARM is to perform an intensive series of atmospheric radiative transfer measurements to validate cloud models and existing radiative transfer codes and ultimately improve the treatment of radiative processes in GCMs. To be successful, these measurements must encompass all climatologically significant conditions that influence large-scale climate, particularly those that interact to produce strong feedback mechanisms.

The focus of the ARM measurements is the basic physics of GCMs. However, these physics are not immutable, as in the sense of a physical law. GCMs integrate elements from theory, basic physics, and observation. They are computational tools and, as such, only approximate reality. This approximate treatment is very much at issue in the discussion of the parameterizations used in the models. As has been described here several times, the use of ARM data is not only to confirm the details of the basic physical processes, but to understand what physical processes and effects must be preserved as the problem is solved in the coarse-resolution GCM case.

The application of the first two criteria, climatic significance and climate sampling, captures the essence of the multiple site problem. The parameterization of clouds in GCMs is so important that it is absolutely necessary to confirm observationally the correctness of those parameterizations in those regions of the globe that are important to climate modeling. More than one region is important. Further, there is sufficient diversity among the climatically important parameters at a particular site that no single site can be thought to adequately explore the meteorology to ensure proper parameterizations for GCMs.

A single location cannot experience all of the necessary conditions to form a definitive study. A single location cannot be found that will experience both a humid tropical climate as well as mid-latitude and subarctic regime. One of the big differences will be in cloud properties, a major focus of this experiment. Low-level tropical clouds are composed of water and water vapor and have temperatures above freezing; ice and supercooled water are usually found in only the upper portions of thunderstorms. Mid-latitude cloud systems are more variable but are predominantly "cold clouds" in winter and at middle and upper levels all year. Other latitude-dependent parameters such as tropospheric depth, varying from 10,000 to 20,000 km, will be important.

Another large difference in cloud properties is determined by the air-mass characteristics during cloud development. Marine air masses contain relatively few cloud condensation nuclei (CCN), the small hygroscopic particles that form the center of cloud droplets. Continental air masses, on the other hand, have a larger number of CCN. As a result of this difference, continental clouds have a high density of small droplets, while marine clouds have a much larger average drop size, but a lower number density of droplets. The ARM experiment must make measurements in all of these conditions to be successful.

The focus of the ARM measurements is the basic physics of GCMs.

Potential ARM Sites and Priorities

As noted above the issue of site selection is a complicated one. The various criteria can lead to conflicting opinions about site viability. Any site selection process is likely to result from a process of compromise among the various criteria. There are, however, several aspects of the site selection process that are fairly certain. The most obvious is that a single site will not meet the stated goals of the program. However, there are several classes of potential sites which are very high priority. The first of these includes regions of the globe that are important drivers of climate, such as the tropical ocean, or are currently predicted to be highly sensitive to climate change. Finally, the suggestion that pollution can affect cloud properties is one that demands careful study. The priorities associated with these three classes of potential ARM sites are discussed here, as an illustration of the application of the site selection criteria.

Climate-Sensitive Regions

Current climate models suggest that particular geographical regions are quite sensitive to the effects of greenhouse gases. Among the specific effects that have been suggested are the amplification of the climate warming signal at high latitudes and the net drying of mid-latitude, mid-continental sites. The secondary effects of these suggested sensitivities are particularly interesting. High latitude temperature ranges have an important effect on the polar snow and ice cover and consequently, the planetary albedo. Mid-latitude, mid-continental sites are particularly important in contemplating effects, for example, on domestic agriculture and mid-western water supplies.

As potentially climatically sensitive areas, there are several issues of importance. First, if the basic parameterizations of unresolved subgrid processes are incorrect in these areas, the sensitivity of the areas may be either under-

overestimated. Improper characterizations may in fact be the cause of the current apparent sensitivity of these regions to carbon dioxide induced climate effects.

In any case, the process of assuring that parameterizations and radiative forcing treatments are correct in these sensitive areas appears quite important. It is difficult to imagine that some region specific idiosyncracies would not creep into parameterizations validated in that region. The ARM mobile observing system will be used to test for such biases. However, parameterizations that are biased in favor of correct treatment of climatically sensitive regions are more acceptable than any other.

Ocean Regions

One of the most interesting and challenging site choices for ARM would be an ocean site. There is no better illustration of the tension between scientific merit and logistical viability. The oceans cover 73% of the Earth's surface and exchange heat, gases, and energy with the atmosphere. The upper 3 m of the ocean has the equivalent heat content of the sum of the entire atmosphere and surface of the land masses combined. To a first order, the upper ocean is mixed to between 200 and 300 m. Thus, the upper ocean buffers the variations in atmospheric temperature on decadal time scales. The ocean is a major source of cloud condensation nuclei and the major source of water vapor for cloud formation. It is a source and sink for atmospheric CO₂ and other greenhouse gases. Measurements of the radiative forcing over the oceans are crucial to understanding atmospheric radiative forcing in GCM's, yet such measurements are scarce. Consequently, atmospheric radiative forcing over the oceans is poorly understood.

The oceans themselves have distinct radiative regions. For example, consider the short wavelength sunlight reflected by the upper ocean. The subtropical and tropical ocean basins, which comprise the largest surface area of the ocean, are characterized by optically clear waters with

low concentrations of absorbing particles. Such waters, called case 1 waters by optical oceanographers (Jerlov 1976), reflect approximately 10% of the solar radiation in the blue. In contrast coastal waters, with high particle loads and high concentrations of dissolved organic materials (case 2 waters), can absorb 99% of the incident visible ultraviolet radiation. Case 1 waters account for about 75% of the ocean surface (Kirk 1983); thus radiative measurements at an ocean site characterized by case 1 waters are more representative of the "global ocean" than coastal measurements. High resolution, high precision, spectral measurements, supported by meteorological and ancillary oceanographic data can be made in a campaign mode using ships and/or aircraft, however some measurements, such as water vapor flux, sea surface temperature and spectral reflectance will be compromised by boundary layer effects of the platforms themselves. Additionally, such platforms are expensive and difficult to support continuously or for extended periods.

Islands are logistically more easily supported platforms for radiative and ancillary measurements, however, it should be recognized that many volcanic, mid-ocean islands induce their own local climatology (the island mass effect). Atolls are potentially suitable sites because of their profile, however atolls are coral outgrowths. Coral skeletons are composed of calcium carbonate, which is highly optically reflective. Additionally, planktonic biota found in the waters in the immediate vicinity around atolls often contains organisms with calcium carbonate skeletons. Thus measurements of the surface ocean reflective radiation field made from an atoll may be badly biased relative to the true case 1 condition which may exist only a few kilometers from the atoll itself. Alternate platforms, such as old oil-drilling platforms, may therefore be important locations for deploying equipment.

Aerosol-Impacted Regions

Another consideration in selecting a siting strategy for ARM is the possibility that other anthropogenic factors may be affecting the Earth's

radiation budget. A body of work (Twomey et al. 1984; Charlson et al. 1987; Schwartz 1988; Wigley 1989) suggests that industrial atmospheric emissions, particularly sulfur dioxide, by enhancing the concentration of aerosol particles that serve as CCN, thereby increasing their visible light albedo. This phenomenon has potentially significant implications on the Earth's radiation budget and on the interpretation of changes in radiative forcing over the industrial era and is expected to be the subject of much study in the next several years.

This phenomenon is particularly important from the perspective of ARM. Cloud microphysical properties must be considered when computing the radiation field at the surface for comparison with the measured radiation field. This radiative flux is expected to depend on the concentration of droplets within clouds, which are affecting surface radiation at any given measurement situation, of aerosol particles in pre-cloud air. Therefore it is advantageous, from the perspective of stressing the model, to conduct measurements in situations corresponding to a wide range of loading of pre-cloud aerosol particles.

Given the plan to establish a number of ARM sites, it would be beneficial to locate one site in an area that is minimally impacted by anthropogenic aerosols and another in an area that is heavily influenced by such aerosols. For example, the island of Tasmania is frequently in air that is minimally influenced by anthropogenic aerosol (Ayres et al. 1986) and would provide an excellent case of a "pristine" site. In contrast, the Northeastern United States is frequently subject to substantial aerosol pollution transported from the Ohio River Valley region (Schwartz 1989) and routinely impacted by aerosol-related effects.

If it is not feasible to conduct measurements simultaneously at both "pristine" and "impacted" locations, a single site at a location such as upstate New York or Western Massachusetts might be considered. Differences in large-scale circulations in the air that are present in this region lead to a wide range of loading of aerosol particles and cloud droplet concentrations. At

One of the most interesting and challenging site choices for ARM would be an ocean site.

Whiteface Mountain in New York (Pueschel et al. 1986), number densities of cloud droplets (CD) and interstitial particles (IP) within clouds indicated the passage of a wide range of air masses. These included maritime (St. Lawrence Gulf-Gaspe Peninsula, CD=64 cm⁻³), background continental (North of Lake Superior, CD=130; IP=220) and polluted continental (Pittsburgh-Southern Great Lakes, CD=750, IP=3600). In such regions, a wide range of aerosol-related, cloud-microphysical properties may be sampled at a single site.

Proposed Data Management Strategies

The goal of the data management effort of ARM is to provide a high quality experimental data set which can be linked to a wide range of models. The emphasis will be to give the users convenient access to data that have been checked for internal consistency and properly reduced. The system design strategy emphasizes the use of existing technology in software and hardware. Large-scale development work will be kept to a minimum. The data management effort will use existing data centers for dissemination and archiving.

An estimate of the raw data volumes generated at each site is seven gigabytes per day. This translates to almost a megabit/second data transfer rate. Real-time quality control algorithms must be applied to this enormous volume of data to assure accurate information and correct interpretation. The data must be readily available at the local control center and at analysis sites remote from the experimental sites.

The data must be well documented and archived for future reference and analysis. Under some circumstances it will be necessary to merge other data streams with the ARM data stream. Satellite data and the data from instruments used during specialized observing campaigns will be an important element of meeting the

scientific goals of the program. The design of the ARM project presupposes a well designed, smoothly functioning, research data management system.

Each of the ARM sites will have a local computing facility. Data from the various instruments at a given site will be merged and made available on-line for input to models and quality assurance procedures. This distributed computing approach provides important system reliability. Problems at one site will not affect archiving and collection at another site. Each site will be able to be remotely interrogated. The on-line data can be transferred to a central site for archiving or for use by researchers on other computer systems. In order to simplify the use of ARM data sets, the central site will convert data to a standard format such as the Common Data Format (CDF) developed by NASA. The ARM quality assurance effort will generate a complete audit trail, including documentation of all changes in instrumentation, calibration and validation.

Radiation models will be used to predict the measurements made by the radiation instrument outputs. Other ARM data will be the input to the models. It will be very important to keep detailed records of changes in model algorithms and instrument calibrations which result from these inter-comparisons. The quality assurance effort will be standardized and follow the same procedure at each site. The resulting "meta-data," i.e., information about the data should also be standardized for all sites.

The ARM project will be a long-term experimental investigation that will evolve with time. The data management system must meet initial needs, but must be designed so that it can evolve along with the project. The management of the data stream produced by the instrument suite for an ARM site presents a challenging problem to the design of the data system. The real-time nature of the analysis and the need for continual access to the data by remote users demand an aggressive and innovative approach. However, as with the measurement equipment, the success of ARM is dependent upon the timely deployment of well-understood

The ARM project will be a long-term experimental investigation that will evolve with time.

technologies. This section describes how data for the ARM Program will be managed, including the data flow, an overview of the system architecture, and the relationship of this data system to various national climate data centers.

Data Flow Overview

Although the project, and therefore the data management support system, will evolve, there are several basic conceptual processes and principles which will govern system development. We begin with a general overview of data manipulation and flow.

Figure 17 shows a representation of the processes and feedbacks associated with the ARM data. Data are collected on site (level zero data, L_0) and real-time quality control procedures applied. This yields level one (L_1) data. These data provide direct feedback to experiments in progress. This process takes place primarily at the Local Control Center, and yields information

used by the principal investigators. These data are also critical to the quality control cycle for the equipment and must be processed within hours.

The next step is the analysis of the data by project researchers individually or in groups. The analysis process entails the active development and testing of radiation models and cloud parameterizations. This process naturally applies another quality assurance level to the data. This process which will take place at the home institutions of the PI's, yields L_2 data, and takes from days to weeks to accomplish. It provides feedback not only to the ongoing experiments, but also raises questions which will prompt the development of new experimental processes and procedures.

The final step is the full quality assurance of the data sets, full documentation, and distribution to the general research community. Additional information will be merged frequently with the experimental data sets to produce derived data products of value to a more diverse research

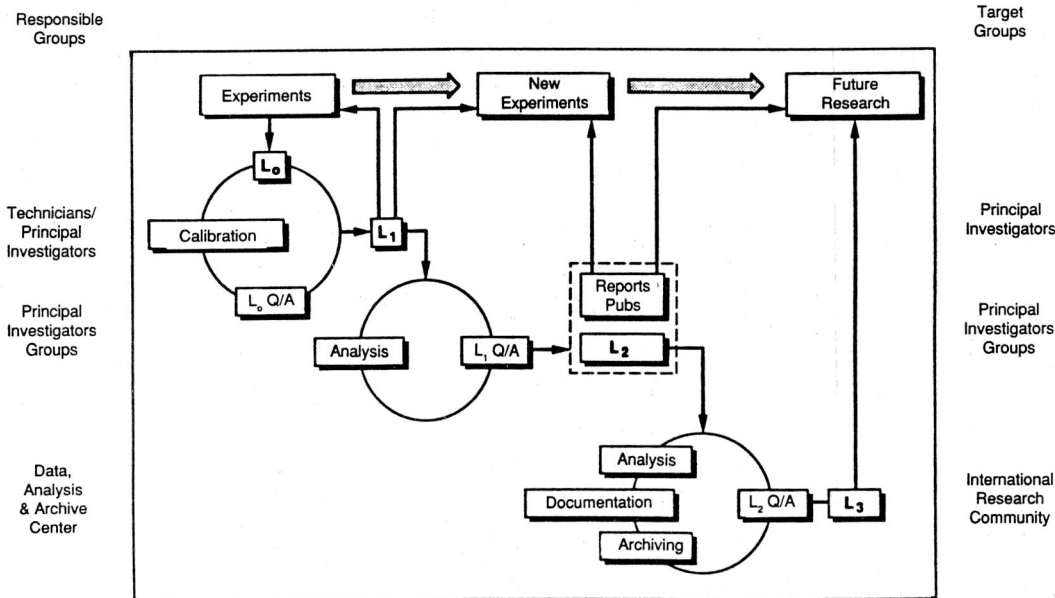

Figure 17. Conceptual design of ARM data flow.

community. The process, yielding L_3 data, takes place at a central data analysis and archive center. At this central facility, data sets from all of the sites will be maintained as a research resource.

In another view of the data system, one can describe it as made up of data collection, fusion, and verification, networked communication, and archival database storage/retrieval systems. The large quantity of data to be collected, processed, and cataloged in database format makes each of these components a particular challenge.

Data Collection, Fusion, and Verification

The experimental program consists of data collection at four to six separate geographical locations. At each location there is a central facility which has the task of characterizing the atmosphere through the measurement of temperature, vapor concentrations, spectral radiation and other physical parameters. A great volume of data generated in the central observing facility will come from the Fourier transform interferometers, which will generate as many as one million data points as often as ten times per hour. The system used to map the three-dimensional distribution of meteorological conditions, which surrounds the central core, will probably generate the largest volume of data. The resulting data rates are estimated at 1 Mbyte/minute of reduced data generated from 3 Mbits/second of raw data. The effective data rates from the extended observing sites will be small. For the current discussion the data rate for all of the extended sites is estimated to be equal to the data rate of the core site.

The most demanding portion of the experimental design is the process of driving the various models with the meteorological data and the direct comparison of the model's outputs with the data from other instruments. The following sequence covers that process.

- Measurement. The collection of the data from the meteorological instruments, radiometric

instrumentation, three-dimensional mapping system and extended sites.

- Data Fusion. The generation of the altitude-dependent meteorological parameters and the three-dimensional grid of cloud data in a format compatible with the modeling routines. This may involve the incorporation of data not collected by ARM, such as satellite data.
- Modeling. The calculation of predicted observations for each of the sensors measuring radiation or cloud properties and that made their measurements concurrently with the initial meteorological observations.
- Comparison. The comparison of the results of the theoretical calculations to the physical measurements.

This sequence highlights the fact that the critical data product of ARM is the differences between the observed and calculated radiation field. The major objective of ARM is to improve radiation modeling and cloud parameterizations. The measured data must therefore be subjected to substantial quality assurance efforts. We propose considerable computational effort during the data collection cycle to assure that the data are valid. This includes the meteorological data driving the models and the radiometric data. These computations must take place in "real time" during the data acquisition phase. This is the best way to prevent the generation of large quantities of comparison data in which the differences are caused by instrument failure.

In considering the data quality control process, it is useful to consider the various measured quantities as being classified along three different axes. First, the same measurements may be performed at different times, making temporal displacement one of these axes. Further, measurements may be taken in separate locations, providing spatial displacement as the second axis. Finally, there are several different types of sensors, providing a redundant check for quantitative displacement as the final axis which characterizes a measurement. Our general

... the critical data product of ARM is the differences between the observed and calculated radiation field.

approach is to construct control models describing the behavior of various measurements when displaced along these three axes. These models are the basis of the consistency checks among the data.

At the lowest level, for example, we examine the raw output of each individual sensor. The first quality assurance measure is to verify that the values obtained from the sensors are within acceptable operational ranges. In addition, a control model describing the behavior of sensor measurements separated in time can be compared with the observed sensor behavior. These models are probably very simple, but may detect troubles very quickly. For instance, a model of a thermometer may assert that the temperature change between two successive readings must be less than some threshold.

Another collection of models may correlate different types of measurements. For instance, radiometric measurements in one wavelength interval may be used to compute bounds for reasonable values in another interval. Models describing spatial displacement of measurements provides another axis for consistency checking. Such models for temperature or pressure, for instance, may detect unreasonable spatial gradients for these quantities.

The transformation of the raw sensor output into the "published" data provides more opportunities for error detection. Many of the meteorological measurements of interest will be available from several different sensor measurements. Thus, the actual generation of the data sets that will drive the models must be performed carefully, taking every opportunity to intercompare contributions from different sensors.

Networked Communications

The communication of data for use away from an ARM site can be separated into two distinct classes. The first class is the transmission of verified data from the collection site to the repository for archival storage. The second communication class is the forwarding of data to

participating research and processing sites for use in the development and testing of climate models.

Since it will not be necessary to transmit the raw data used for the three-dimensional imaging system to the archive, the central station data rate drives the data transmission requirements. The rate will be less than one T1 satellite channel. The transmission rates for the dissemination of data from the archival site to participating research and processing sites depend on the number of sites requiring access and the fraction of the data set that is required at any given time. There will be occasional need for near real-time forwarding of information. Under these circumstances, a reasonable estimate of the data requirements suggests that data rates needed can be met by using existing regional and national networks (i.e., ESNET, ARPAnet, NSFnet). Perhaps the greater concern in this area of communications is to provide a standard flexible and efficient interface for the exchange of information in a distributed environment.

Archival Storage and Retrieval

The database requirements of the ARM Initiative require large bandwidth I/O from mass storage subsystems coupled with fast information processing. Massively parallel processing machines are well suited for database applications. These systems provide mass storage capability. Current technology would be able to handle a total capacity of over 400 Gbytes. Technology currently in design would permit an on-line capacity of 3.5 Tbytes. Using data compression techniques, such a system would hold an entire year of data on-line.

System Overview

The hardware and network overview of the proposed ARM data management system is shown in Figure 18. There are four areas of interest: 1) the instrumentation in the field, 2) the Local Control Center, 3) the Remote Data, Analysis and Archive Center, and 4) the remote users.

The hardware and network overview of the ARM data management system include instrumentation, a local control center, the RDAAC, and Remote Users.

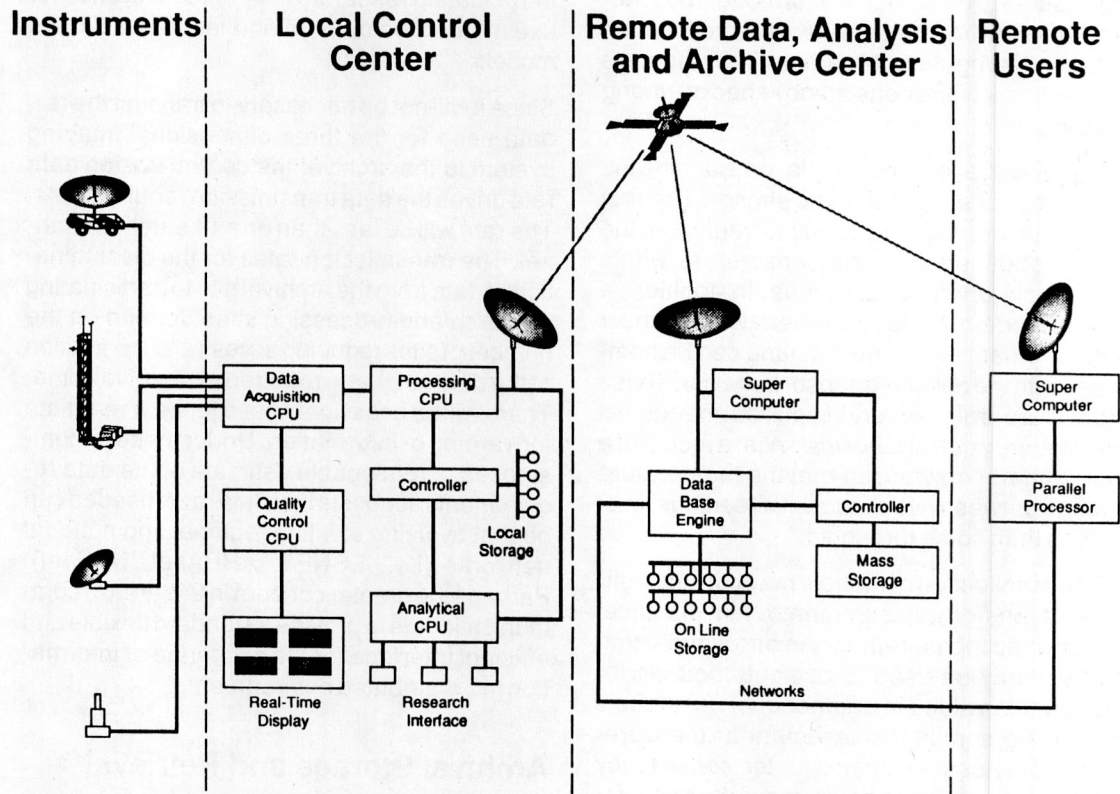

Figure 18. Components of the ARM data management system.

Instrumentation

Where possible, each sensor or group of sensors should be a microprocessor based intelligent front end designed for harsh environments. For most of the complex instruments, the processor is generally part of the instrumentation package. Whenever possible the data stream will be accepted in its most processed form from the processor associated with the instruments. This will be part of an attempt to minimize software development cost and complexity. Exceptions will be made only if the on-board processing is incompatible with the quality assurance goals for the system.

The front end processors absorb some of the data manipulation overhead and minimize processing time on the data acquisition CPU. This technique provides expandability to any sensor node, user configuration, autonomous node control, and independent telemetry. The communication system for linking the instruments to the CPU will operate in a variety of modes to optimize network bandwidth.

Local Control Center

The Local Control Center would be a building on-site from which local operations could be managed. For mobile locations, the Local Control Center could be housed in busses or semi-trailers.

At the Local Control Center the incoming sensor data streams would be polled by a Data Acquisition System. This system would be a real-time, interrupt-driven processor dedicated to monitoring the instruments. The data would be passed from this Data Acquisition CPU to dedicated Quality Control and Processing systems. The Quality Control system will apply real-time algorithms to check the validity of the incoming data streams.

The processing CPU accepts data streams in various instrument output formats and reformats them into a smaller number of common formats for more efficient downstream processing. The processing system then passes the data to the satellite uplink to the Remote Data, Analysis and Archive Center (RDAAC), and to the Controller for Local Storage. Data can be stored locally for only one to three days due to its volume.

The Local Control Center also houses an analytical system which accesses recent data on Local Storage through the common Controller. The analytical computer is used by researchers on-site to run predictive models and compare output to the current data stream. The control center also has access through its satellite link to the entire historic experimental data set back at the RDAAC. Data and models at remote user sites will also be accessible through satellite or via ground networks accessed by the RDAAC. Models that are too large to run locally will be run on supercomputers back at remote sites through satellite and ground network lines.

Remote Data, Analysis and Archive Center

The need for a RDAAC is driven by a number of issues. The data volume will be approximately 100 kilobit/second. These data streams will come from each experimental site and necessitate a large "data engine." Long-term quality assurance, documentation and distribution functions require a permanent staff and facility. There is a

need for a highly networked, central repository for both the database and models.

The Local Control Center will be linked to the RDAAC via a two-way satellite link due to the large data volume anticipated. The Local Control Center will also be linked to remote users. This will support access to real time data via satellite or subsets of the real-time data stream indirectly from the RDAAC over land networks. The RDAAC will also have supercomputer access to support large models and analyses that cannot be handled by the Analytical CPU on site. The RDAAC will perform final quality assurance checks, archive and distribute the data to the research community.

Whether the RDAAC needs to be a dedicated facility or could be incorporated into an existing data center will be determined by the final system requirements.

Remote Users

Researchers at remote sites will access the ARM data in three ways:

- If they need real-time access to the entire data stream, they will connect to the Local Control Center via satellite link. From their remote locations they can monitor the data streams as they are received from the instruments. It will also be possible to run programs that reside at the Local Control Center.
- If they desire access to a subset of the real-time data stream and do not have satellite linking capabilities, they can receive data passed to them by the RDAAC over conventional land networks (ESNET, NSFnet, ARPAnet, etc.).
- They may desire access to both historic and current ARM data but lack the computational facilities necessary to process the data locally. In this case, they can access the database and use the computational facilities for analyses.

Relationship to Other Data Systems and Centers

Like many of the climatic data sets being generated by other agencies the ARM data set will be of interest to a community that is broader than the small circle of ARM investigators. The timely dissemination of this data and the analytic results to that community will be an item of importance to the ARM project.

The National Aeronautics and Space Administration (NASA), the National Center for Atmospheric Research (NCAR), the National Oceanic and Atmospheric Administration (NOAA) and the Department of Energy (DOE) have existing data centers. These centers will be informed and provided with copies of ARM data for their archives.

The DOE has established a DOE Carbon Dioxide Information Analysis Center at Oak Ridge National Laboratory to provide its researchers with relevant climatological data. The center's emphasis is on data quality assurance and documentation to insure that valuable global research data sets will be usable to future researchers. The currently available data sets include data from the Historical Climatological Network (HCN) and data on global CO₂ emissions.

The NASA Master Directory at the Goddard Space Science Center, Greenbelt, Maryland, keeps brief summarized information about available Earth (land, oceans and atmosphere) and Space Science (space physics, solar physics, planetary science and astrophysics) data sets on-line. The directory is a free service which can be accessed from many computer networks as well as via dial-in lines. The directory describes data from NOAA, the United States Geological Service (USGS), NCAR, and other agencies in addition to NASA as well as from academic institutions and other organizations throughout the world. It has an emphasis on including data sets relevant to the study of global change. The directory is a part of the Catalog Interoperability

(CI) project, a cooperative effort among NASA, NOAA, USGS, academic institutions and several international organizations. The CI effort is aimed at providing the science community with an interconnected data information network which will permit users to efficiently determine the location, nature, and applicability of data throughout the world.

NASA's National Climate Data System (NCDS) which is an element of the National Space Science Data Center (NSSDC) at Goddard keeps data sets on-line along with analysis tools for the use of NASA's global change researchers. Data available via NCDS includes solar activity and irradiance, clouds and radiance, global climatologies and oceanographic and atmospheric composition data. The purpose of NCDS is to provide an integrated set of tools for climate researchers to locate, access, manipulate and display relevant data. NSSDC has developed a Common Data Format (CDF) into which all data are transferred prior to display and analysis. The CDF is a self describing data structure and includes software for data access.

NCAR has available a variety of climatological data sets, which it disseminates routinely to researchers, principally in the academic community. The NCAR collection includes climatological data at grid points and monthly data at stations. A specialty has been the collection of sets of daily and monthly analyses, especially from operational weather centers. The archives include data from selected climate model experiments for changed CO₂. Data sets of surface and upper air observations and for oceanographic variables also are available.

NOAA climatological data is made available to researchers through its National Climatic Data Center (NCDC). The NOAA data sets include a catalog data base, the Climate Inventory and Catalog (CLIC); a Historical Climate Network (HCN), developed with funding from the DOE CO₂ program, which includes 95 years of record for 1219 stations; and a surface reference data center for calibrations and validation of satellite data consisting of 20 sites around the world. The Satellite Data Services Division (SDSD) of the

NCDC manages all NOAA satellite data archive holdings and provides a variety of satellite data services to the retrospective data user community. The NCDC is forming a Global Climate Laboratory to develop reference data bases for use in model testing.

Research Needs: Remote Sensing and Laboratory Spectroscopy

While many of the basic goals of the ARM Program are within the grasp of current technology, there are important areas of instrument development that could provide direct benefit to the program. These areas fall into two classes: improved remote sensing and radiometric instrumentation and laboratory spectroscopy.

Remote Sensing and Radiometric Instrumentation

The single most important area of technology development for the ARM Program is in the remote sensing of the microphysical properties of clouds, in particular the measure of liquid water content and the droplet size distribution. Beyond these basic commodities, there are others that will prove of interest as well. Among these are the chemical composition and number density of CCN. In the absence of remote sensing methods that can reliably measure these parameters, the ARM Program will be required to use in situ sampling with aircraft to determine these critical parameters.

The plan for bringing new technology into the ARM Program and into operation at ARM installations has two parts. The first part will be a

series of general solicitations for proposals in particular technology areas. Two areas are already anticipated as being the basis of such a solicitation—cloud property remote sensing and three-dimensional cloud imaging systems. The second approach is to incorporate the technologies developed by other agencies as it reaches operational status. In this case, the ARM sites will be made available to other programs for testing, calibration, and demonstration of new instrumentation concepts.

The next most important area for investment in instrument development is radiometric instrumentation. The ARM Program will place extremely heavy demands on the performance of radiometric measurement and calibration methods. Improvements in radiometric instrumentation and observing protocols can be translated directly into improved testing for radiative models and cloud parameterizations. The approach to development for radiometric instrumentation will be that outlined for remote sensing instrumentation, ARM-specific development, and support and testing of development in other agencies and programs.

Laboratory Spectroscopy Program

The subtleties of atmospheric chemistry make it impossible for laboratory experimentation to fully characterize atmospheric radiative properties. However, there are very definite, specific areas in which laboratory spectroscopy can provide important insight. The ARM program plans to pursue these studies diligently as an integral part of its measurement strategy. An area of study that could benefit from laboratory investigation is that of atmospheric opacity.

Atmospheric opacity is at the heart of the calculation of GCM radiative transport and is therefore central to the determination of radiative interactions and energy balance. In principle, atmospheric opacity is obtained from line-by-line calculations performed of molecular bands. The line-by-line calculations yield band averages

or opacity distribution functions which can be parameterized for GCM calculations. It is important for GCM radiative calculations that the line opacities be of as high an accuracy as possible. The recent Intercomparison of Radiation Codes used in Climate Models (ICRCCM, Luther et al. 1988) makes it clear that problems remain in line opacity data.

As a part of the ARM Program, the fundamental opacity data will be reviewed and updated in a selection of models in order to minimize the errors from this source. This work can include, where required, further laboratory efforts and assessment of databases as they currently exist and develop. Particularly important problems, as pointed out within ICRCCM, are the water-

vapor continuum and the associated question of line wing theory; it is also of importance to include the latest available data for the radiatively important trace gases.

It is worth noting that a significant area of activity exists in the weapons effects community to develop accurate air opacities at many wavelengths and in both the troposphere and stratosphere. The Geophysics Laboratory (GL), the Jet Propulsion Laboratory (JPL), and the Los Alamos National Laboratory (LANL) maintain efforts in this field that could be utilized profitably with ARM. The ARM Program plans to both benefit from and contribute to these complementary efforts through its laboratory spectroscopy component.

Management Plan

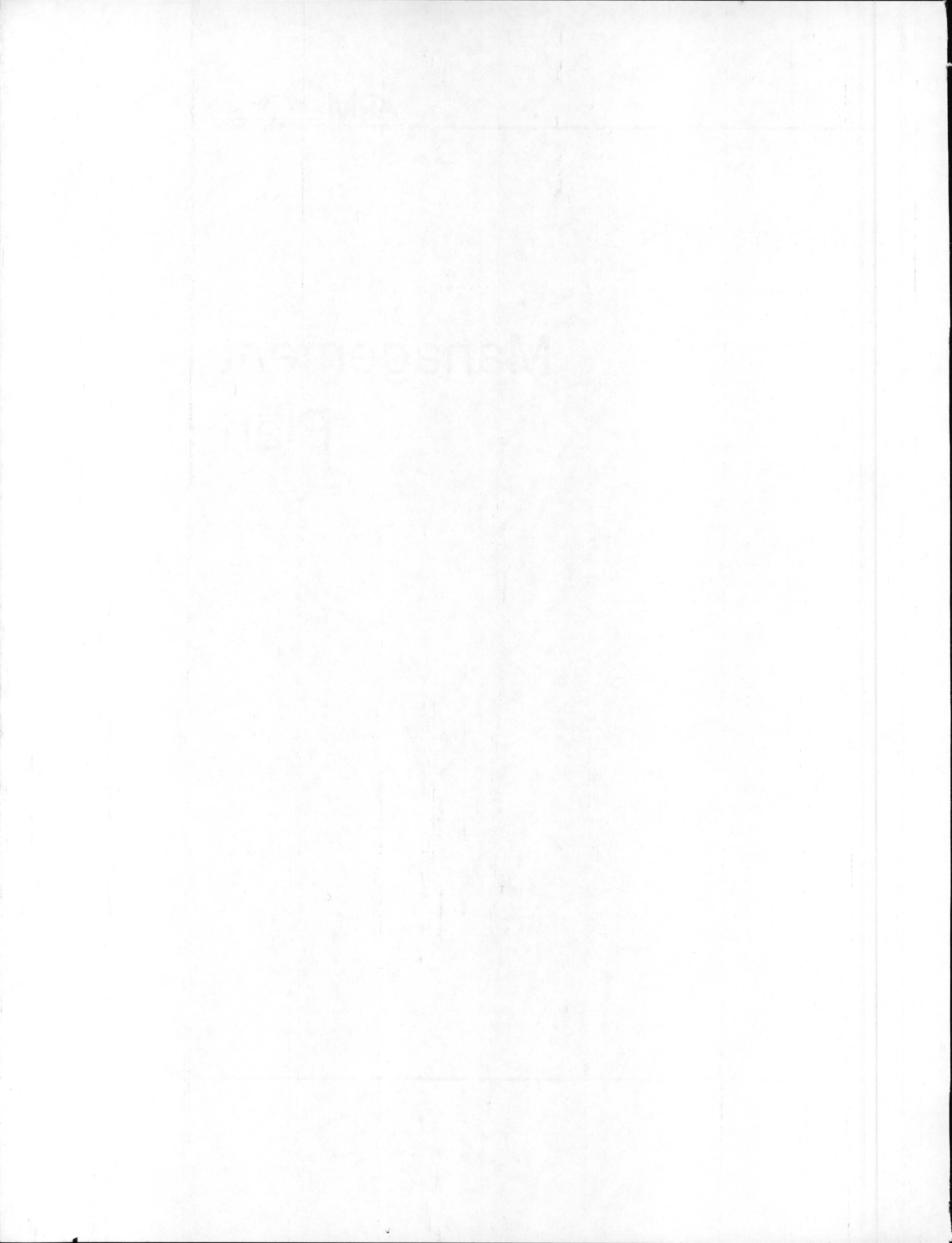

Management Plan

This section describes the management structure and approach for the ARM Program. The description includes the DOE oversight of the ARM, the management of ARM on an operational basis and during program startup, and the relationship of the program to other national and international activities. A schedule and budget are also provided.

Management Structure

The planned management and organizational structure for the program appears in Figures 19 and 20. Figure 19 shows the direct management of the Program by the Atmospheric and Climate Research Division (ACRD) of DOE's Office of Health and Environmental Research. ACRD will be supported by an active Interagency Steering Group to ensure close coordination with other agency-led programs. Some of these programs and their relationship to ARM are described in the Relationship to Other Programs part of this section.

Within the ARM Program itself there are three major programmatic elements and a project office. The three internal elements of ARM, the Science Team, the Cloud and Radiation Testbed (CART), and the Instrument Development Program, will be managed on a day-by-day basis through a project office which will be responsible for the general coordination and scheduling of major ARM activities. Final management approval and oversight will be retained by ACRD.

The functions of the three programmatic elements are:

1. A strong Science Team will set the scientific and intellectual direction of the program. It is

made up of two groups. The first, the project scientists, will be selected based on peer review proposals to conduct specific scientific programs with the ARM facilities and data. A second group will be selected by DOE to provide an interface with existing programs both within DOE and other agencies. The representatives of the other scientific programs will be designated by those programs or the agencies responsible for their conduct. Subgroups currently contemplated within the Science Team will focus on particular issues such as GCM and radiative modeling, cloud parameterization, and advanced remote sensing methods.

2. The Cloud and Radiation Testbed (CART) will serve as the experimental framework and infrastructure in the project. CART, which was described in the Experimental Design Section and whose management is described later in this section, includes the fixed experimental sites, a mobile complement of instrumentation, and a series of focused campaigns aimed at particular scientific issues. All elements will be drawn together by a shared data system that will provide ready access to major experimental results for the Science Team and other investigators.
3. An Instrument Development Program will support ARM and CART in two significant ways, as a place for new and innovative instrumentation to be developed in response to the needs of ARM and as a pathway for instruments developed outside of ARM and DOE to be introduced into the operational ARM environment.

The three elements of ARM will be funded independently by ACRD using a combination of competitive proposals, interagency transfers, and funding to the DOE laboratories. All Science

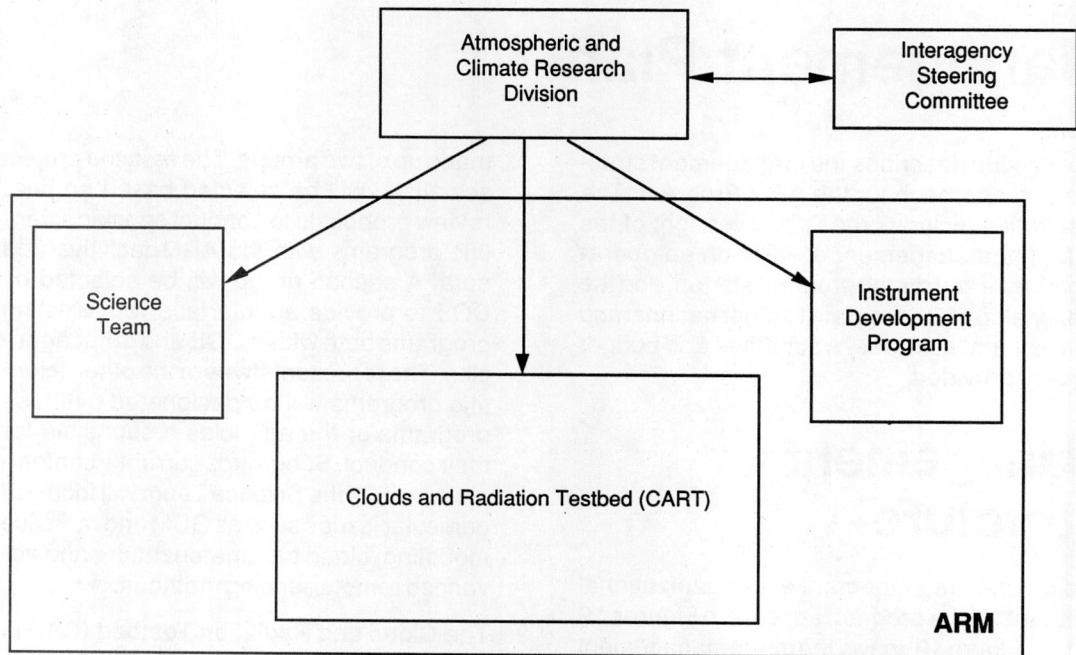

Figure 19. DOE oversight of ARM showing the Interagency Steering Group and the three programmatic elements of ARM.

Team research will proceed through competitive review process regardless of the status of the institutional affiliation of the principal investigator, be it university, private industry, DOE laboratory or non-DOE laboratory. The Instrument Development Program will be funded through several processes, including the review of unsolicited proposals, directed development, and inter-agency transfer of funds to obtain the unique capabilities of other government agencies. The funding of the CART will follow a similar plan with overall management provided through the DOE laboratory system. However, individual sites or campaigns may well be operated by universities, other laboratories or private contractors.

Management of the Clouds and Radiation Testbed

Within CART there will be several basic functions which will be organized into a series of teams with specific tasks and charters. The team approach within ARM has been selected because of breadth of participation expected in the program. The teams will be used to bring together the technical talent from many institutions to achieve specific ARM goals.

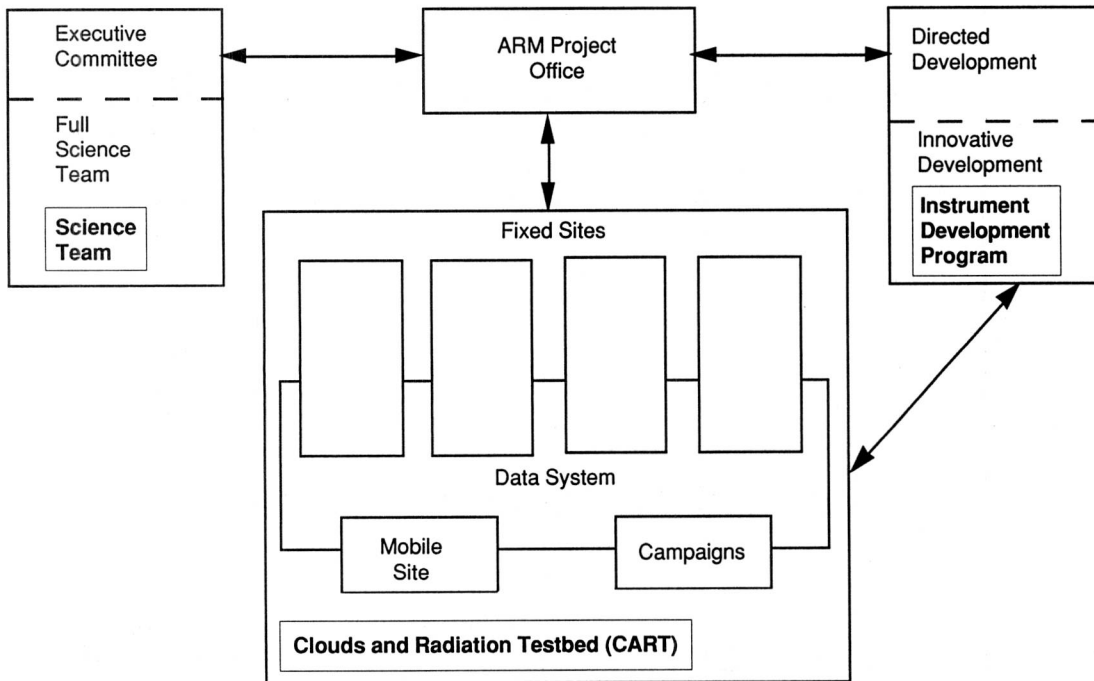

Figure 20. Internal Management of ARM.

- The modeling team will be responsible for the development and maintenance of a set of models to be used for data quality assurance and to serve as a set of “community models” for the Science Team. The selection, design, and implementation of these models will be conducted under the guidance of the Science Team.
- Instrument teams will be formed around particular parts of the experimental program. These teams will ensure integration of the experimental program within the overall program objectives. It is currently expected that there will be teams associated with the meteorological remote sensing, the radiometric instrumentation, the extended site instrumentation, and calibration. The goal of these teams is to develop, deploy, and integrate instrumentation at the individual research sites and provide a transition to the groups responsible for operation of the equipment and the data system. The selection of the final instrument complement will be approved by ACRD based on the recommendations from the Science Team and a review panel.
- The data management team will be responsible for the design, development, and deployment of the data management and analysis system for the Program. Unlike the operations team, which will be organized around the operation of a particular site, the data management team will have program-wide responsibility.

- The operation teams will be formed by the project office around the management and operation of the individual sites and the mobile system. The goal of these teams is to provide for the smooth operation of the individual sites. Responsibility for the operation of individual sites will be determined on the basis of logistical considerations and could be contracted, assigned to a DOE laboratory, or operated by another federal agency.
- Campaign teams will be formed on an ad hoc basis around the conduct of a particular campaign or activities need to be coordinated with another program. Each campaign team will be responsible for the development and maintenance of liaison with the operational teams as required to support campaign activities.

Implementation of the ARM Program

The implementation and startup of the ARM Program involves several activities which will begin in the first year and will gradually evolve into the operational structure described in the previous section.

The basic activities are the design of the project infrastructure, the formation of the Science Team, and the initiation of the Instrument Development Program. These activities will proceed in parallel until the initial complement of Principal Investigators is selected and the Science Team is in place.

Design of the Project Infrastructure

It is impractical to suggest that ARM can be meaningfully constructed out of a combination of independent investigations or that the Science Team should be empowered as a management entity to provide the detailed design and development of CART. Therefore, in the first year of

the program a basic framework for CART will be created. This framework will be used to make early design decisions and to provide a reasonable basis for the early recommendations and decisions of the Science Team. The ARM project office will be responsible for developing this framework.

During the first year the following products will be developed:

- A candidate list of instruments for deployment in the first phase of occupation of the first ARM site. This candidate list will be supported by complete instrument descriptions and will include a recommendation for instruments that will be absolutely essential to meet the ARM mission, a set of options for meeting specific measurement requirements, suggested calibration protocols for each of the instruments, and a list of instruments that are recommended to the Science Team as possible instruments beyond the basic complement. This list, the associated descriptions, and other information will be used by the Science Team to prioritize the acquisition and deployment of the ARM instrumentation.
- A list of candidates for the first ARM site and a methodology for selecting that site. The list of candidate sites will be supported with descriptions of the sites. The site selection methodology will include criteria for selection and will be used by the Science Team to make a recommendation to ACRD for the selection of the first ARM site. The criteria will include those outlined in the section on Program Design and others.
- A recommended suite of models to be used both for data quality control and to serve as "community models" for the project. In addition to supporting the models of the individual principal investigators, CART will need models to support quality assurance activities. It also would be useful to have a generic set of models of different atmospheric processes that are either regularly run for the general benefit and reference of the Science Team or

that the Science Team may use to support specific elements of their own research. The development of both classes of models will be undertaken with the guidance of the Science Team.

- A preliminary data system design and data system implementation plan. The data system is critical to the success of ARM and provides the basic of access for the Science Team and the rest of the research community to the ARM data and results. A basic design is required if the Science Team is to understand the consequences of siting, modeling, and instrumentation decisions on the performance of the overall data system.

While these four products are being developed to support the Science Team, it is essential that they be developed in dialogue with the technical community. As a result, the project office will convene a series of workshops with broad community participation that will act as a "surrogate" Science Team prior to the final Science Team selection. The results of these workshops will support the development of material for eventual use by the Science Team and CART.

Formation of the Science Team

In the first year of the program, the most important activity will involve the creation of the Science Team by general solicitation to the scientific community for proposals for participation in the ARM Program. The Science Team will have two distinct elements, one related to modeling and the other related to supporting laboratory efforts, most notably laboratory spectroscopy.

GCM, Radiative, and Cloud Parameterization Modeling

The most important element of the early activities of the Science Team will be to refine the plan for the use of ARM data in the development of

improved radiation and cloud parameterization models in GCMs. The first Science Team meeting will include a workshop which will focus on this issue. Following this workshop, several activities are expected to begin. First, a working group on radiative modeling will be formed. This group will begin the acquisition of radiative modeling codes for incorporation in the ARM testbed. In conjunction with this activity, model sensitivity studies, which were begun under ICRCCM, will continue.

Similarly, a working group on cloud parameterization will be formed. This group will have the much more difficult task of designing the strategy for developing and testing of the ARM cloud parameterization models. The activities of this group will interact strongly with the development of the cloud and cloud-water remote-sensing systems. As noted below, this is an area in which instrument development will be proceeding from the very early stages of the program.

Finally, a working group on GCM implementation of ARM results will be formed. This group will use their GCMs to examine the consequences of the ARM results. This implementation cycle, in which the ARM results find their way directly into the GCMs, is very important. Not only will the results from these implementations satisfy the goals of ARM, they will also shape the direction of future ARM activities.

Laboratory Spectroscopy Program

Achieving the goals of ARM will require a supporting program of laboratory spectroscopy. The ICRCCM concluded that:

"Uncertainties in the physics of line wings and in the proper treatment of the continuum make it impossible for line-by-line models to provide an absolute reference..."

Luther et al. 1988

Thus, no present-day model furnishes an absolute standard by which to judge other models. Early in the ARM implementation there

will therefore be a general solicitation for participation in the ARM Program directed at laboratory spectroscopists. The intent is to put in place a laboratory spectroscopy program whose agenda is guided by the results of the ARM experiment.

Instrument Deployment and the Instrument Development Program

The ARM instrumentation strategy has several features: continual improvement of operational performance of individual instruments, rapid incorporation of new measurement technologies, and both directed and exploratory instrument development efforts. In keeping with this philosophy, the focus of the instrument teams must be to bring instruments to operational status and to maintain them in that state.

Review of Existing Instrument Systems

The current Program Plan contains suggestions for the ARM instrument complement. This instrumentation needs to be reviewed by the Science Team, the initial instrument complement selected, and the procurement activity initiated. Although the program will begin with the best available equipment, some development effort will be required to bring more experimental instrumentation to operational status. For the major remote sensing instruments associated with the central facilities, this process will take the form of an ongoing readiness review followed by a staged integration into the final system.

Packaging the Extended Observing Site Systems

The preliminary selection of equipment for the extended observing sites includes equipment that is well understood and ready for field operations. However, given the number of extended

stations, 16 to 25 per site, partially automated operation can help achieve considerable long-term savings. It is not likely that these systems can be brought to a stage of automation that would require less than one visit every three to four days. But because that level of automation would be extremely advantageous, it will be an early goal of the instrument program, working in collaboration with the community involved in the Global Baseline Surface Radiation Network.

The Long-Term Instrument Development Program

The philosophy of continuous improvement of the ARM measurement system necessitates an active Instrument Development Program. The need for development will be examined continually throughout the ARM field experiment. Individual development efforts will begin in direct response to the ongoing scientific needs of the program, and the resulting instruments will be introduced into the system as they become ready for operation.

There are several areas in which important instrument development activity is already in progress or needs to be initiated. For example, the equipment for routine, remote characterization of cloud properties does not exist. There are, however, major development efforts under way at a variety of laboratories directed at improving the situation. One of these, at NOAA's Wave Propagation Laboratory, is described below.

Another area of interest is the remote sensing of cloud properties. As indicated in the design, the plan for the initial operation of ARM calls for direct sampling for cloud properties, such as liquid water content, droplet size distributions, and relative water and ice content, by using an aircraft. In the longer term, a remote sensing system is more desirable.

Similarly, a second area of development with respect to cloud properties would be a cloud visualization system. This system would define the outer envelope of clouds, the importance of which was presented in the Experimental Design

Section. This system will be a major element of the three-dimensional mapping network.

Formation of the Data Management Team

While the data management strategy for ARM lies well within the performance envelope of existing technology, the design of the system needs to begin as quickly as possible. The initial activities, which will ramp up to the final system, center on the development of the final requirements for the basic data system, both at the local site and at the archive and analysis center.

Among the major issues for the system design are:

- the development of the interfaces and the interface standards for the experimental equipment
- specification of the data exchange formats for the passage of physical and meteorological data to the radiative models and the comparison of the radiative data with the model predictions
- integration of the ARM data streams with those of the National Weather Service and satellite data streams
- the implementation strategy for the real-time quality control procedures.

The data management team will be formed early in the first year of the program and will be ready to present an initial system design to the Science Team at the end of the year.

Development of an Operations Strategy

The operational strategy for ARM includes a phased approach to the initial deployment of instrumentation at a given site. Following the selection of the first site, pilot observations will begin as soon as practical. These activities will allow early and continuous evaluation of site suitability. The approach will be to ramp the pilot

observing programs up to operational status as the data system and instrument performance warrant. The activities at any site will be deemed operational when the equipment and the data system are sufficiently ready to support the scientific process, as defined by the Science Team.

A critical early activity will be the site selection process. The criteria and considerations for site selection are discussed in the Experimental Design Section. Once the site is selected, site preparation needs to begin as quickly as possible. Several issues require special attention: the siting of the RASS and negotiating locations for the extended observing sites.

Field Test of System Readiness

An important part of the deployment of the ARM experimental equipment will be a system of field trials of increasing complexity. Almost all of the instruments currently anticipated for the initial ARM instrument complement have already been operated in the field. The field tests will therefore focus on the final testing of experimental systems, the interoperability of the various subsystems, and the development of operational protocols.

For example, it is evident that routine measurement of cloud structure and cloud morphology is one of the most challenging aspects of this program. Currently active research is in progress to test and improve instrumentation for this purpose. The NOAA Wave Propagation Laboratory conducted a series of remote sensing measurements of clouds at the Boulder Atmospheric Observatory near Erie, Colorado, from September 6, 1989 to October 5, 1989. This project, called the Cloud Lidar and Radar Exploratory Test (CLARET), was designed to evaluate the combined usefulness of various remote sensors for observations of climatologically significant features of cirrus and other clouds. Many of the features of that experiment closely resemble parts of the ARM experimental approach and illustrate the type of field tests that will precede final deployment of the instruments.

During CLARET the remotely sensed parameters under investigation included cloud-water phase, particle size distributions, height of cloud-bases and tops, the existence of multiple layers, and cloud dynamics revealed through vertical motion measurements. The radiative consequences of the observed clouds were measured at the surface by standard instruments, such as pyranometers, and from space by satellites.

The primary remote sensors from the Wave Propagation Laboratory included two lidar systems, a Doppler radar, and a microwave radiometer. One lidar uses a visible (0.69 μm wavelength) beam and the other is a CO_2 infrared (10.6 μm) Doppler system. Both have dual-polarization capability. The radar is an X-band (3.2 cm) dual-polarization, Doppler system. The microwave radiometer utilizes three wavelengths (1.45, 0.95, and 0.33 cm) to passively measure the amount of water vapor and liquid water along its beam. These systems were routinely pointed toward the zenith during satellite over-passes. At other times, special Velocity Azimuth Display (VAD) and vertical cross-section scans were also utilized to document the winds and to examine horizontal structure of the clouds. In the vertical mode, the Doppler lidar and radar continuously measured the vertical motions in the clouds in addition to backscattering features.

A wide variety of weather conditions occurred during the month of measurements. Conditions included cases of clear sky, pollution layers, cirrus alone, mid-level and multiple layer clouds, decks, low stratus, nimbostratus, and thunderstorms. In some cases only the lidars detected visible cirrus decks, and on other occasions both the radar and lidars detected cirrus. The radar sometimes detected cloud layers aloft when the lidar beams were blocked by the attenuation of low stratus clouds. Information obtained with the remote sensors' different wavelengths and polarizations may provide valuable clues about the cloud particle sizes, concentrations, shapes, and phase (liquid or solid).

From experiments such as CLARET it is evident that a variety of devices must be deployed in

concert, including radar, lidar, and digital photography arrays, for successful conduct of this effort. The plan for ARM is to learn from the experience of CLARET and test the systems in operational settings during the first year and use these experiences to guide the implementation of ARM.

Relationship to Other Programs

The discussion of the importance of the NOAA CLARET experiment at the Wave Propagation Laboratory illustrates the importance of establishing strong contacts between ARM and related programs at other agencies. In this section some of the other programs related to the ARM experiment and objectives are described. These descriptions are not intended to be exhaustive but are intended to represent those programs at DOE, other government agencies, or international scientific bodies which might be expected to interact with the ARM Program.

A major goal of the first year of ARM is to establish effective contacts with these programs. This will be accomplished through the aforementioned ARM Interagency Advisory Committee and by establishing other contacts through the established international programs such as the World Climate Research Program.

There are several ways in which other programs and ARM might interact. First there are programs with complementary research objectives whose results may be of direct interest. If the program is a field program the possibility of coordinated operation of the ARM mobile equipment would be an option as would the collocation of a field program in the vicinity of a permanent ARM site. There also are a variety of long-term field programs and monitoring efforts that already have sites established throughout the world. Interaction with those programs would yield important insight into calibration issues or offer possible sites at which the ARM program could co-locate.

The major goal of the first year is to establish strong contacts between ARM and related programs at other agencies.

Next, there are several programs directly aimed at the development of instrumentation which would be of interest to ARM or to whom the ARM instrumentation might be of use. Finally, there are several important international scientific coordinating bodies that can provide important ties to the international research community.

Complementary Scientific Programs

FIRE and ISCCP (Joint with IRC)

The basic objective of the International Satellite Cloud Climatology Program (ISCCP) is to collect and analyze radiance data sets from space-based sensor measurements to infer the global distribution of cloud radiative properties in order to improve the modeling of cloud effects on climate. ISCCP has operational and research components. The operational component, for which NASA serves as the focal point, has the objective of producing a five-year global radiance and cloud parameter set from data collected through 1990. The research component coordinates regional studies to validate the climatology, to improve cloud analysis algorithms, to improve modeling of cloud effects in climate models, to investigate the role of clouds in the Earth's radiation budget and hydrologic cycle, and to derive surface radiation budget data from satellite radiance data.

ISCCP has several different on-going and planned regional validation programs that involve airborne and groundbased measurements at a number of test areas selected as representative of major cloud types or meteorological conditions. Those in progress include the U.S. sponsored, and NASA led, First ISCCP Field Experiment (FIRE) and the European led International Cirrus Experiment (ICE). FIRE is emphasizing studies of cirrus and marine stratocumulus cloud systems, whereas ICE is primarily concerned with cirrus clouds. Other studies are being planned in Japan and China.

The goals of FIRE complement those of ARM. A cooperative effort involving deployment of mobile ARM instrumentation in support of FIRE is highly likely.

SIFE and ISLSCP

The proposed Boreal Forest Study or SIFE (Second ISLSCP Field Study) proposed by NASA combines elements of ISLSCP (International Satellite Land Surface Climatology Project), the Atmospheric Boundary Layer Experiment (ABLE), and the Terrestrial Ecosystems Program.

As described in the Preliminary Experiment Plan for 1990 to 1995, the goal of the study is to understand the interactions between the boreal forest biome and the atmosphere in order to clarify their roles in global change. The study will be centered on two 20 by 20 km sites located at the ends of a 500 km transect within the boreal forest region of North America. The sites will be the subject of surface, airborne, and satellite based observations. The aims of the observations as stated in the Plan are to:

1. Develop an improved understanding of terrestrial ecosystem-atmosphere interactions in the region; specifically the exchanges of radiation, sensible and latent heat, and trace gases, and to quantify them using remote sensing combined with computer modeling techniques.
2. Develop an improved understanding of the links between surface biophysical (albedo, roughness, canopy resistance); biochemical (trace gas sink/source strength and provenance); and geological characteristics of the biome insofar as they transmit the effects of changes in the physical climate system to the biome or may feed back to give rise to changes in the atmosphere.
3. Understand the links between critical ecosystem processes and those surface states that can be quantified from remote sensing.

There are several important international scientific bodies that can provide important ties to the research community.

The critical point with regard to ARM is that the third objective listed above requires extensive radiometric observations that are resolved spectrally, vertically, and with some angular distribution. At FIFE (First ISLSCP Field Experiment), for example, satellite observations were coupled with aircraft and surface based measurements during the intensive field campaigns. In addition, scanning lidar and balloon-borne meteorological instruments were used extensively.

The exact locations of the sites for the Boreal Forest Study have not been determined. Obviously, the boreal forest biome has a distinct, globally significant surface type and climatology. Generally, the two sites should differ somewhat in climatology, one possibly being in a cool wet area and one in a warm wet area. Thus, one candidate location could be in or near the State of Maine, which could conceivably also serve as an ARM site. Such a location would have the added advantage of being periodically affected by relatively unpolluted continental air masses, relatively polluted continental air masses, and marine air masses.

STORM

The STORM I Experiment is the first of a set of multiscale field experiments planned for the central United States in 1992 and 1993 as part of the National STORM Program. The two primary goals of the National STORM Program are:

- to advance the fundamental understanding of precipitation and other mesoscale meteorological processes and of their role in the hydrologic cycle
- to improve the 0- to 48-hour prediction of precipitation and severe weather events.

The primary goal of the STORM I spring/summer program is to improve the understanding and prediction of mesoscale convective systems (MCSs), their associated weather, and their interactions with larger and smaller scales of motion. Some of the process studies involved with this particular core objective are related to

ARM objectives and include solar and long-wave radiation at the Meso-alpha scale (6 to 24 hour, 200 to 2000 km).

One of the several practical objectives of STORM I is the development of improved cloud-radiative parameterizations in mesoscale and global models. Clearly, this addresses the effect of clouds on the local energy budget, one of the major objectives of ARM.

ASCOT

The DOE's Atmospheric Studies in Complex Terrain (ASCOT; JAM 1989a,b) program has two broad objectives: to improve the fundamental understanding of transport and dispersion processes in complex terrain, and to apply this knowledge to develop methodologies for performing air quality assessments. The ASCOT program has carried out a number of large-scale field experiments, supported by extensive analysis and modeling efforts, to pursue these objectives.

There are several common scientific interests between ARM and ASCOT in view of the importance of the radiative contributions to the energy balances that drive circulation patterns in complex terrain. Conversely, experience obtained in the ASCOT program should be useful in extending the results of ARM to situations in which surface type and orientation, shading, local energy balances, atmospheric moisture content, and cloud cover can change substantially over scales of a few tens of kilometers or less as a result of complex topography.

Hailswath II

The major emphasis of this program is cloud physics studies on the origin and evolution of hail and its importance to the precipitation process. Of the many sub-objectives of the Hailswath II field campaign, one is to test the hypothesis from model simulations (by Tripoli and Cotton 1988 a,b) that cumulus convection occurring in the Colorado mountains can organize MCSs that

participate in the formation of many High Plains mesoscale convective complexes. Specifically, the simulations used short- and long-wave radiation physics, a surface energy budget, warm rain and ice-phase microphysics, and cloud thermodynamics in an explicit cloud model on a two-dimensional domain to study the effects of gravity wave energy on mesoscale convective complexes.

One of the several practical objectives of Hailswath II (like STORM I) is the development of improved cloud-radiative parameterizations in mesoscale and global models. Clearly, this addresses the effect of clouds on the local energy budget, one of the major objectives of ARM.

ICRCCM (Joint with JSC/IRC)

The Intercomparison of Radiation Codes used in Climate Modeling (ICRCCM) is a long standing joint program between DOE and the International Radiation Commission (IRC). The results of this program (see Background Section) have already guided major elements of the design of ARM. It is expected that this relationship will continue during the deployment of ARM.

Long-Term Field and Monitoring Program

GBSRN

The Global Baseline Surface Radiation Network (GBSRN) has been designed in response to the Joint Scientific Committee (JSC) Working Group on Radiative Fluxes (WGRF) recommendation that the World Climate Research Program (WCRP) establish a global baseline network of surface stations to support studies of global climate change. The mission of this network would be:

- to monitor long-term trends in radiation fluxes at the surface
- to provide validation data for satellite determinations of surface radiation budget.

The network is to consist of 10 to 20 strategically located sites, and would take advantage of existing national sites that meet established criteria. The establishment of new and perhaps more technically advanced research sites than presently existing ones is included in the recommendation. The degree to which surface radiation budget research requirements are firmly fixed is not clear at this time. The program would include studies that, at an early stage, will evaluate user requirements and the structure of the surface radiation field and determine the specific need for additional measurements. ARM, as indicated in the Experimental Design Section, will be closely coordinated with GBSRN.

LTER

The Long Term Ecological Research Program (LTER) is sponsored by the National Science Foundation's Division of Biotic Systems and Resources. Currently, a total of 15 sites are located in the United States, including two in the State of Alaska: one in tundra, one in taiga, one in temperate rain forest, two in dry mountain shrub and forest, one in dry grassland, two in humid grassland and parkland, two in Great Lakes mixed forest, four in eastern deciduous forest, and one in tropical savanna. The ecological structure and processes in natural landscapes are studied at temporal scales of decades or longer. These sites offer the opportunity for use of a well-managed site with controlled access, provided disruptions to ecological systems are minimal. For example, the Konza Prairie Natural Research Area in Kansas is an LTER site (humid grassland) that was used extensively by NASA's First ISLSCP Field Experiment.

ParkNet

DOE/OHER's Environmental Research Parks (ParkNet) consist of six sites with landholdings of up to 2300 square kilometers. Ecological studies have been conducted in park areas for up to 40 years. The parks are located at National

Laboratories with multidisciplinary staff onsite. While studies have been devoted mostly to ecological research, the parks potentially provide very convenient areas for many other types of research sponsored by DOE/OHER, including ARM studies.

NADP/NTN

The National Atmospheric Deposition Program/ National Trends Network (NADP/NTN) is the largest wet deposition monitoring network, with over 200 sites collecting weekly precipitation samples in North America. The program is driven by effects research needs. Although the focus of the network has been acidic precipitation since 1978, current effects research have indicated that a reduction of surface uv-b radiation may have a significant effect on crops and forests. A strawman is currently being prepared that proposes uv-b radiation measurements be made at a selected subset of NADP/NTN sites. Such long-term, routine measurements at a number of sites across North America would provide a basis for comparison of the representativeness of ARM measurements.

MAP3S

The Multistate Atmospheric Power Production Pollution Study (MAP3S) wet deposition research network provides daily sampling and composition of precipitation at 9 sites in eastern North America. Although the focus of the program since 1978 has been on acidic precipitation and wet removal processes, the program is currently developing a strawman that proposes to increase the number of MAP3S sites to distance source/receptor regions (i.e., Bermuda, Nova Scotia), and make atmospheric chemistry and turbidity measurements to investigate the anthropogenic influence on Cloud Condensation Nuclei (CCN) and cloud formation in the Atlantic Ocean. As in the NADP/NTN effort, routine measurements at a number of sites in eastern North America and in the Atlantic would provide a basis for comparison of the representativeness of ARM measurements.

Instrument Development Programs

Listed here are three programs that are focused on the development of laser-based remote sensing systems. The technologies represented here are of particular interest to ARM.

Cloud Base Measurement Project

The cloud base measurement project has initiated the Experimental Cloud Lidar Pilot Study (ECLIPS) during 1989 and 1990 which has objectives to:

1. demonstrate feasibility of obtaining a long-term climatology of cloud base and optical depth.
2. improve methods of satellite cloud retrieval.
3. obtain a data set of cloud optical properties complementary to the ISCCP data set. The data would be handled through a designated data center to the NCDS NASA Climate Data Center.

LITE

The goal of this program is to probe the upper and lower regions of the atmosphere with optical elastic backscatter measurements from a space platform—the first use of lidar technology from space in a civilian program. Scheduled for operation from a U.S. space shuttle in the spring of 1993 under the sponsorship of the NASA Office of Aeronautics and Space Technology (OAST), the overall thrust is to provide data that will validate models of atmospheric properties related to the backscattering data, viz., cloud top and planetary boundary layer heights, tropospheric and stratospheric aerosols, and temperature and density from 10 to 40 km.

A key feature of this program is the evaluation of lidar instrumentation in a space environment, both from an operational point of view and from the perspective of developing insights into the development of next-generation lidar systems.

Following this first implementation of the LITE probe, plans for proposed succeeding efforts include utilizing the lasers that will permit DIAL measurements of water vapor, temperature, and pressure.

LASE

The aim of the LASE program is to use DIAL technology to measure water vapor, aerosol, and cloud profiles from a high-altitude aircraft platform. LASE is planned for implementation in the spring of 1991 on a high-altitude ER-2 (extended range U-2) aircraft.

When operational, LASE will contribute information about the hydrological cycle and atmospheric transport using water as a tracer of atmospheric motions. Aerosol and cloud data from elastic backscatter will give new understanding to atmospheric structure and transport as well as to meteorological parameters. Study of visible and subvisible aerosol/cloud layers will allow evaluation of their importance for interpreting passive satellite measurements and radiation budgets. A key feature of the LASE system is the simultaneity of the water, cloud, and aerosol data acquisition, which will permit significant advances in understanding the scientific results acquired when compared to earlier separate-variable experiments.

International Programs

International coordination is very important to ARM. Many of the World Climate Research Program activities will have specific field programs, such as FIRE/ISCCP, noted above.

IRC Activities

There are several working groups of the IRC that have goals complementary with the ARM initiative. A short description of these working groups is given below.

ITRA

For the past few years the Intercomparison of Transmittance Algorithms (ITRA) has devoted its activities to intercomparing results of calculations from different detailed radiation models using the same input meteorological data. These comparisons, like those of ICRCCM, have shown considerable inter-model differences. The main goal of the next ITRA campaign is to compare model computed transmittance and radiance with observed data using observed atmospheric data as input to the models.

ASA

The Atmospheric Spectroscopy and Applications (ASA) effort has a variety of sub-groups dealing with important problems in atmospheric spectroscopy, including: line parameter compilations, continua of N_2 , O_2 , H_2O ,...; pseudo-continua of heavy molecules such as the "Freons" and HNO_3 ; and specific planetary problems and applications (e.g., non-LTE effects).

IGAP

The objective of the International Global Aerosol Program (IGAP) is to improve the understanding of the role of atmospheric aerosols in the forcing mechanisms and forecasting of changes in global climate, and in geospheric-biospheric processes. IGAP plans to accomplish this objective by: 1) the establishment of global aerosol climatologies, 2) the standardization of measurement and analysis procedures for monitoring global aerosol characteristics and for validating models, 3) the organization of regional and process-specific field experiments and studies, and 4) the implementation of information exchange mechanisms.

Working Group on Radiation Fluxes (Joint with JSC/IRC)

The terms of reference for the JSC-IRC Working Group on Radiative Fluxes are:

1. to advise the JSC (Joint Scientific Committee) on climate-related radiation problems

2. to take initiative, with the help of the WCRP Radiation Projects Office, to promote research activities and instrument development programmes, as appropriate for the fulfillment of the WCRP radiation information requirements
3. to serve as the focal point for cooperation with the International Radiation Commission of the International Association of Meteorology and Atmospheric Physics (IAMAP) and the Commission for Atmospheric Sciences of WMO in the field of radiation sciences
4. to review and report annually to the JSC progress made in the WCRP Radiation Projects and related international research activities
5. to assist with the organization of workshops or symposia on climate-related radiation research, with a view to expanding the participation of the radiation science community in WCRP.

Working Group on Clouds and Radiation

The general purpose of this working group is to focus on defining and promoting those research areas of common interest to both the radiation and cloud physics communities. This group is jointly sponsored by the International Commission on Cloud Physics (ICCP).

WCRP Activities

The World Climate Research Program (WCRP) has a wide variety of international programs that are of direct interest to the ARM Program.

WOCE

The World Ocean Circulation Experiment (WOCE) is a multiyear, multinational field measurement program in physical and chemical oceanography designed to provide critical parameters for improving ocean circulation models. A major goal of WOCE is to develop a better understanding of meridional heat fluxes. Measurements of the upper ocean heat fluxes and air-sea interactions have been drastically

trimmed since the WOCE inception, and the United States WOCE's surface layer activities which are related to radiation budgets will be restricted to measurements of sea surface temperature from drifters, meteorological measurements from volunteer ships of opportunity, and possibly long- and short-wave radiometric measurements in the eastern North Atlantic in 1983.

GEWEX

The Global Energy and Water Cycle Experiment (GEWEX) is planned for the 1995 to 2000 period, and its goals, as summarized by WMO (1988) are:

1. to determine the hydrological cycle and energy fluxes by means of global measurements of observable atmospheric and surface properties
2. to model the global hydrological cycle and its impacts in the atmosphere and the ocean
3. to develop the ability to predict the variations of global and regional hydrological processes and water resources, and their response to environmental change
4. to foster the development of observing techniques, data management and assimilation systems suitable for operational application to long-range weather forecasts, hydrology and climate predictions.

In order to measure the components of the planetary radiation budget at the top of the atmosphere, and infer net radiation at the surface, GEWEX will require a combination of precisely calibrated, broad-band earth radiation measurements from several spacecraft in low earth orbits and coincident determination of the three-dimensional cloud distribution, including information on the altitude of cloud base (WMO 1988). The latter data will be obtained from a new generation of satellite lidar instruments. As with TOGA, the estimation of surface radiation budget components will require the use of accurate radiation models, the calibration of which can be performed with ARM data. Furthermore,

these estimation techniques will likely require cloud parameterizations of the type to be tested and developed by ARM.

TOGA

The scientific objectives of the Tropical Ocean - Global Atmosphere (TOGA) program are as follows (from NRC 1986):

1. to determine to what extent the time-dependent behavior of the tropical oceans and related planetary-scale circulation patterns are predictable on time scales ranging from weeks to a few years, and to understand the mechanisms that give rise to this predictability
2. to explore the potential of coupled atmosphere-ocean system models for predicting climatic variability on these time scales and, within the context of that predictive capability, to develop an observing and data management system to support operational climate prediction.

The TOGA program will require data sets for surface energy fluxes over tropical oceans for model verification and boundary conditions at the atmosphere-ocean interface for atmospheric and ocean models. The surface radiation fluxes will be estimated from a variety of techniques, but almost all of them will make use of radiation models and satellite observations. TOGA has called for the net surface radiation flux to be estimated to within 10 W/m² on a monthly-average. ARM will contribute to achieving this goal by narrowing the range of uncertainty of model calculations. This will in turn lead to better estimation techniques for estimating surface radiation budget parameters from satellite radiance observations.

WGNE (Joint with CAS/WMO)

The WGNE (Working Group on Numerical Experimentation) advises the JSC of the WCRP and the Commission on Atmospheric Sciences (CAS) of the WMO on a broad range of issues related to numerical modeling in both numerical weather prediction and climate simulation. Of

particular relevance to DOE interests in the climate area is the WGNE's activity in establishing standards for model experimentation and intercomparison. The WGNE has endorsed the DOE-sponsored international climate model intercomparison activity being led by Robert Cess, and is coordinating the DOE Program on Climate Model Diagnosis and Intercomparison at the Lawrence Livermore National Laboratory, with other international efforts in this area.

Schedule and the Deployment of ARM

The ARM schedule is shown in Figure 21. In a program of this size, a milestone chart can appear quite complex. There are, however, several critical milestones that deserve some attention and comment.

April - Year 3 (tentatively 1992)

First Site Operational (installation begins six months earlier)

This milestone is one of the most important ones for the program. This will be a phased deployment as described previously.

Summer - Year 3 (tentatively 1992)

Mobile Site in Coordinated Campaign with FIRE (Depends on FIRE Schedule)

The goal in this case is to make radiative measurements in support of an interagency program focused on cloud physics and cloud parameterization. The current rate of technology development suggests that this experiment will field several state-of-the-art cloud-water remote sensing systems for the first time.

Summer - Year 4 (tentatively 1993)

Readiness Review of Cloud-Water Remote Sensing

Following instrument development and FIRE field experience, advanced cloud-water measurement capability to be added to ARM sites.

ARM will then be providing operational test capability of both radiation budget, cloud formations, and parameterization models based on remote-sensing techniques.

October - Year 4 (tentatively 1993)

Fourth Site Operational

This site is the last currently planned in the budget of ARM. Its deployment will mark the end of the initial deployment phase of ARM. Addition of sites and the duration of site occupancy will then be a subject of continuing scientific review.

April - Year 5 (tentatively 1994)

Five Year Scientific Review

This review will cover several critical issues, the first of which will be to refine the long-term strategy for the application of ARM data to evolving GCMs. By this time the GCM modeling team will have made several sensitivity studies using

the early ARM results. These results will be used to guide the evolution of the ARM observational program. Next will be a review of the complete observational program. Major issues such as expanding or contracting the number of sites will be addressed.

Budget Projections

The basic budget for ARM, described in terms of years of operation is shown in Table 3. This budget represents a preliminary distribution of funds based on current understanding of the project. It is sufficiently accurate to cover the budgetary envelope for the project. Adjustments among the categories are quite probable. The distribution of funds reflects the evolving emphasis in different parts of the program. The budget for ARM and the associated schedule is shown in Figure 21.

Table 3. ARM budget in millions.

| | 1 | 2 | 3 | 4 | 5 | 6 | 7 | 8 | 9 | 10 | Total |
|--------------------------------------|---|-----|----|----|----|----|----|----|----|----|-------|
| Management Administration: Workshops | 1 | 3 | 4 | 5 | 5 | 5 | 4 | 4 | 3 | 3 | 37 |
| Science Team Activities - Total | 3 | 6.5 | 8 | 11 | 15 | 15 | 14 | 11 | 12 | 13 | 109 |
| GCM Sensitivity | 1 | 1 | 1 | 2 | 3 | 4 | 4 | 4 | 5 | 6 | 31 |
| Cloud Parameterization | 1 | 2 | 3 | 4 | 6 | 6 | 6 | 4 | 4 | 4 | 40 |
| Radiative Modeling | 1 | 3 | 3 | 4 | 5 | 4 | 3 | 2 | 2 | 2 | 29 |
| Laboratory Spectroscopy | | 0.5 | 1 | 1 | 1 | 1 | 1 | 1 | 1 | 1 | 8.5 |
| Instrument Teams - Total | 4 | 19 | 26 | 37 | 32 | 32 | 14 | 4 | 4 | 0 | 172 |
| Equipment Readiness | 2 | 4 | 2 | 2 | 2 | 2 | 2 | | | | 16 |
| Equipment Acquisition | | 12 | 20 | 25 | 25 | 25 | 10 | 4 | 4 | 0 | 125 |
| Instrument Development | 2 | 3 | 4 | 10 | 5 | 5 | 2 | | | | 31 |
| Data System Operations - Total | 1 | 5 | 7 | 7 | 5 | 5 | 6 | 4 | 4 | 4 | 48 |
| System Design & Development | 1 | 4 | 5 | 5 | 2 | 2 | 2 | | | | 21 |
| Data Operations | | 1 | 2 | 2 | 3 | 3 | 4 | 4 | 4 | 4 | 27 |
| Operations - Total | 0 | 1.5 | 5 | 10 | 13 | 13 | 12 | 12 | 12 | 15 | 93.5 |
| Site Development | | 1 | 2 | 2 | | | | | | 3 | 8 |
| Operational Cost | | | 2 | 6 | 10 | 10 | 10 | 10 | 10 | 10 | 68 |
| Campaigns | | 0.5 | 1 | 2 | 3 | 3 | 2 | 2 | 2 | 2 | 17.5 |
| Total by Year | 9 | 35 | 50 | 70 | 70 | 70 | 50 | 35 | 35 | 35 | 459 |

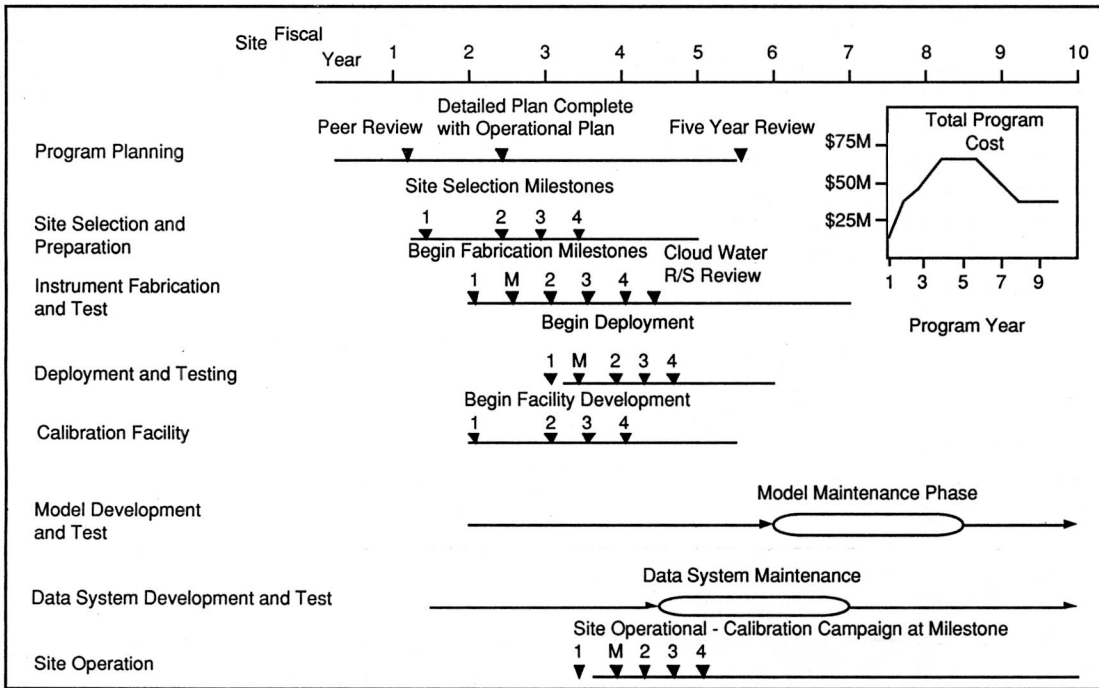
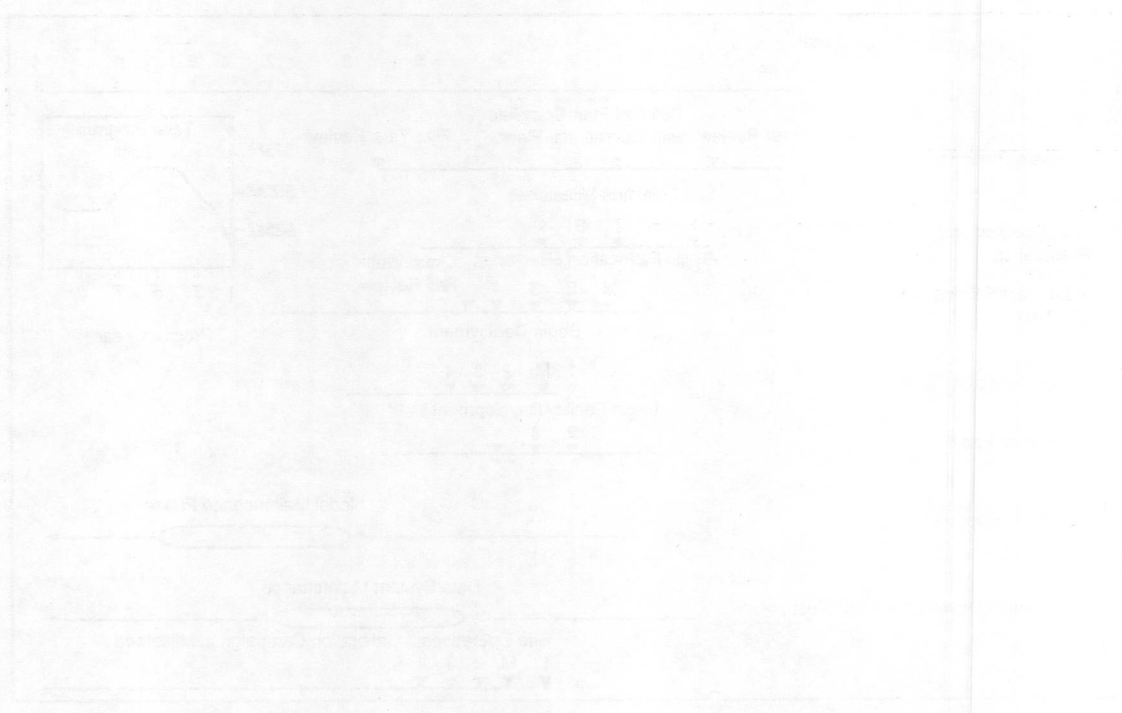

Figure 21. Atmospheric Radiation Measurement Program schedule and budget for four (1-4) fixed sites and one mobile (m) site.

Page 1 of 1



Page 1 of 1

Appendixes

1974

Appendix

Appendix A

Brief History of the Department of Energy Carbon Dioxide Research Program

In 1977, the National Academy of Sciences challenged the scientific community on the subject of energy and climate by stating that "To reduce uncertainties and to assess the seriousness of the matter, a well-coordinated program of research that is profoundly interdisciplinary in character, and strongly international in scope, will be required."

Responding to this challenge and the growing concern about the long-range consequences of carbon dioxide emissions resulting from ever-increasing fossil fuel combustion prompted the Department of Energy to undertake a thorough examination of the carbon dioxide (CO₂) problem. The first step was to convene a Workshop on the Global Effects of Carbon Dioxide from Fossil Fuels in 1977 at Miami Beach, Florida. Some 75 scientists discussed the state of knowledge of the CO₂ cycle and the consequences of increases in atmospheric CO₂. The workshop identified significant gaps in understanding, and recommended actions to fill those gaps.

Based upon this information, the Department of Energy organized the Carbon Dioxide and Climate Research Program with initial funding in FY 1978. The goal of this research program was the identification of possible policy options for governmental action in response to changes in the atmospheric CO₂ concentration. Achievement of this goal requires increased understanding of CO₂ interactions with the atmosphere, the biosphere, the oceans, and the cryosphere and the resulting changes on critical resources and human welfare.

In 1978, Congress enacted the National Climate Program Act to establish a comprehensive national policy for dealing with all climate-related issues. Responsibilities under the Act involve several government agencies. In full cooperation with this program, DOE has been assigned lead agency for coordinating the government's research efforts in the area of atmospheric CO₂. Within the DOE, this responsibility has been carried out by the Carbon Dioxide Research Division (CDRD) of the Office of Basic Energy Sciences, Office of Energy Research (OER), now the Atmospheric and Climate Research Division, Office of Health and Environmental Research (OHER).

In 1979, the DOE sponsored the American Association for the Advancement of Science to conduct a Workshop on the Environmental and Societal Consequences of a Possible CO₂-Induced Climate Change. This meeting brought together 85 scholars and 28 contributed papers. The workshop was a difficult but timely first step in identifying questions to be addressed by climate impacts research. Prior to this workshop there had been no discussion of secondary effects on potential consequences of global climate change. One important, tangible outcome was the realization that CO₂ directly affects plants, and that the Earth's vegetation could change irrespective of climate. This finding led to expanded research (with the USDA) on the direct effects of CO₂ with plants, which has now become the primary data base for determining combined CO₂ and climate effects with crops and ecological systems.

The scientific community conducted an analysis of global greenhouse research results in 1984-1985 under the auspices of the DOE. This review by DOE and other national and international researchers produced four state-of-the-art reports and two companion volumes. This analysis determined what is scientifically well-known about the greenhouse effect, what is

known with less certainty, and what remains largely unknown. Findings of the state-of-the-art reports pointed to four major research needs. First, General Circulation Models must be compared to observed data and to each other to understand where and why the different models agree and disagree. Second, uncertainties in General Circulation Models concerning clouds and oceans must be reduced to provide reliable estimates of regional climate change. Third, whole-system (crop, ecosystem) data and models must be developed for evaluating the effects of climate and carbon dioxide change. Finally, the effects of variable carbon dioxide and climate change on the world's resources must be evaluated.

The Carbon Dioxide Research Program has evolved through this process. The continuing goal is to provide adequate scientific knowledge to the government and others for identifying and selecting responses to the greenhouse effect (i.e., climate change and CO₂ fertilization, and their simultaneously induced influences on natural and human resources).

Appendix B

Current Measurement Technologies

This appendix describes the general features of the measurement systems from which the proposed ARM instrument complement was selected. It is intended for those readers with little background in the proposed instrumentation. Further reading can be found in the reference list of this Program Plan. The discussion is organized similar to that in the Experimental Design Section of this Plan. Part 1 contains descriptions of radiometric instrumentation, while Part 2 deals with meteorological instrumentation.

Radiometric Measurements

Radiometric instrumentation is a critical component of the ARM experiment. This discussion of the existing technology is divided into instrumentation used for the study of shortwave radiation (0.3 to 3.0 μm), which is characteristic of the direct solar beam and scattered solar radiation, and for the study of longwave radiation, characteristic of thermal radiation re-emitted by the atmosphere and the Earth's surface.

Shortwave Instrumentation

Instrumentation in this wavelength regime, 0.3 to 3.0 μm , will collect information relating to the incident solar flux on the Earth's surface. In general this regime is divided into two components: the direct and the diffuse. The direct beam is defined as that portion of the solar flux that is neither absorbed nor scattered during its flight

from the top of the atmosphere. The diffuse component is generally defined as those photons incident on the Earth's surface that are scattered such that their direction, but not their energy, is changed by interaction with atmospheric constituents.

Broad-Band Instruments

Pyranometers

A pyranometer is used to measure the global (i.e., direct and diffuse) radiant flux (Watts per square meter). There are several types of pyranometers available from various manufacturers. One of the most common errors of pyranometry, and perhaps the most difficult to eliminate, is the "cosine effect" produced by the instrument response being a function of angle of incidence of the radiation. The second most important source of error is the temperature response of the instrument, even in units that are supposedly "temperature corrected." The precision and accuracy of the currently available pyranometers vary markedly, even between two pyranometers of the same model and manufacturer. This is due to the instruments having different angular and temperature response functions.

If very thorough calibration and characterization methods (as discussed in the Experimental Design Section) are used to quantify a specific pyranometer's response function, then a total measurement uncertainty of about $\pm 2\%$ (4% range) is possible. For the better instruments, a precision of $\pm 1\%$ (2% range) is possible. Such measurement accuracy and precision are not possible without each instrument being carefully characterized with respect to all other instruments that might be used in an experiment.

The temporal resolution, or minimum time constant, of pyranometers is approximately 30 seconds. From the standpoint of spectral

resolution, pyranometers can be used with hemispherical colored glass filters to provide very coarse spectral measurements. Using various combinations of instruments and filters one can obtain the following spectral bands: 0.285-0.525 μm , 0.285-0.630 μm ; 0.285-0.700 μm ; 0.285-0.780 μm ; 0.525-2.80 μm ; 0.630-2.80 μm ; 0.700-2.80 μm ; and 0.780-2.80 μm .

Pyrheliometers

An alternative approach to using a pyranometer is to use a pyrheliometer to measure the direct-beam and a shaded pyranometer to measure the diffuse component; then adding these components to obtain the global flux. When a strong direct-beam is present, this method is more accurate than using a single pyranometer because a pyrheliometer does not have the angular response uncertainties. An active cavity pyrheliometer can measure the direct-beam with a total uncertainty of only 0.3%. Assuming that the diffuse component is 15% of the global flux, and that the uncertainty of the shaded pyranometer is 2%, an uncertainty of only 0.6% is possible for the total global flux. For clear days (i.e., a diffuse component less than 20%), this method is superior to using a single pyranometer.

Rotating Shadowband Radiometer

The Rotating Shadowband Radiometer (RSR), shown in Figure 22 is a microprocessor controlled instrument that uses a single detector to measure the global, direct, and diffuse short-wave irradiance on a surface. It is possible to incorporate a bandpass filter with the detector such that the measured components are for a narrow spectral region. The detector has a view angle of 180 degrees. The device uses a silicon photodiode detector and a microprocessor controlled shadowband to make the required measurements. The overall accuracy is better than 6%, being somewhat dependent on whether the detector is spectrally filtered.

Because of the spectral response of silicon, broad-band measurements of the direct and

diffuse irradiance must be corrected (Michalsky et al. 1989). Calibration is required semiannually against an absolute cavity radiometer for broad-band measurements and a spectral lamp for narrow-band measurements. Measurement accuracy requires consideration of the spectral, temperature, and cosine response. The RSR instrument is an operational instrument currently used primarily in research applications.

Spectral Instruments

Scanning Filter Photometers

Scanning photometers are computer-controlled altazimuth instruments that can be programmed to point to and measure any position on the sky. They are primarily used for multispectral all-sky radiance mapping and as an active tracking sunphotometer. A mirror is used to direct the incoming radiance onto a fixed photodiode detector. The instruments generally use a filter wheel to make measurements in narrow-band (10 nm) spectral regions. The field of view is typically 1.5 degrees.

The instruments can be absolutely calibrated but are primarily used for optical depth measurements, which require only relative units. The precision is ~1%. In a radiance measurement program the instrument should be calibrated against an absolute cavity radiometer and the filters checked against a spectral line source semiannually.

Spectral Sunphotometry

The state of the art in spectral sunphotometry is fairly well advanced in terms of experience with instrumentation and field operations. Maintaining stable calibration of sunphotometers seems to be the most critical problem to deal with. It can be handled best with a program of frequent cycling (currently 6 months to 1 year) of instruments to a calibration facility. Careful design that includes quality components for the instrument is essential. Sunphotometers are usually calibrated using the Langley method. The best

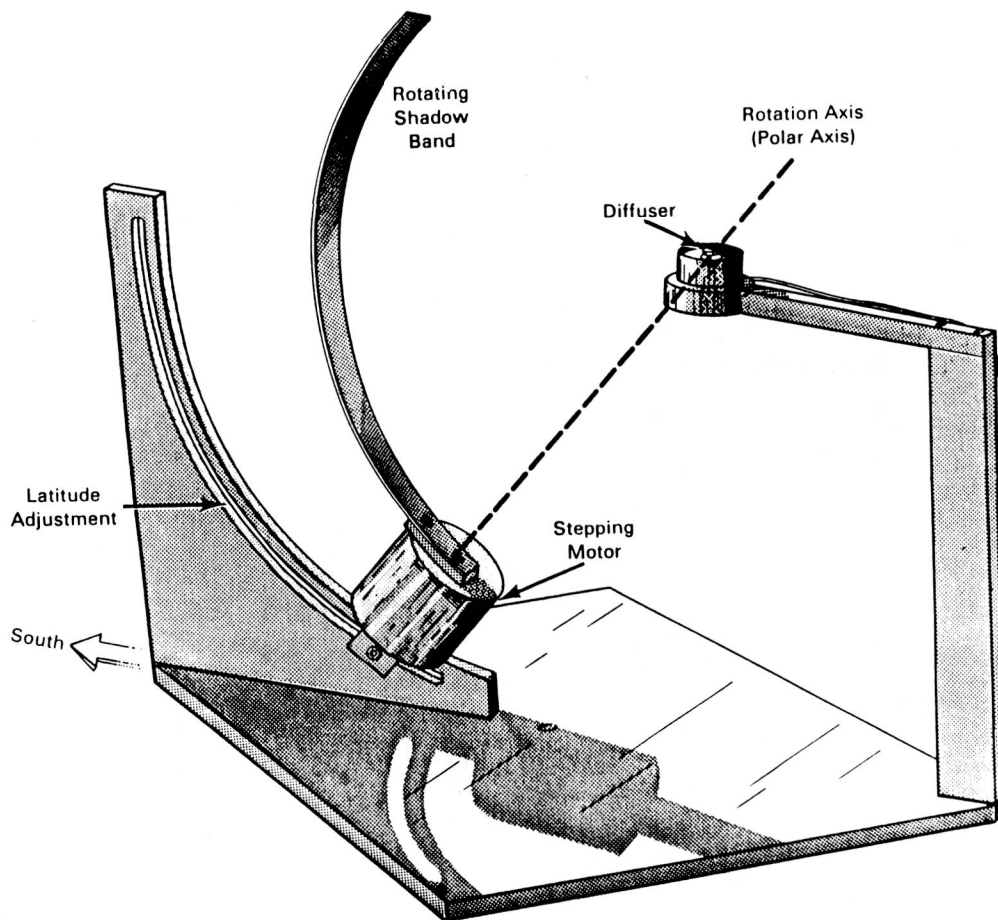

Figure 22. The Rotating Shadowband Radiometer.

location for this method is from a high elevation such as Mauna Loa or in the Rockies, because atmospheric conditions change too rapidly at lower elevations. This method is work-intensive and therefore expensive. The Solar Energy Research Institute (SERI) has developed a Sunphotometer Laboratory Calibration System (SLCS) capable of detecting changes in a sunphotometer response of less than 0.5%.

Rotating Shadowband Spectrometer

The Rotating Shadowband Spectrometer (RSS), shown in Figure 23, is a microprocessor controlled instrument that makes spectrally resolved measurements of the global, direct, and diffuse

irradiance on a surface. The detector has a view angle of 180 degrees. The instrument uses the geometry and operational algorithm of the RSR to derive the irradiance components in conjunction with a double prism lens system to disperse the incoming light. A 256-element linear diode array is used to instantaneously sample the dispersed spectrum between 400 and 1000 nm.

The spectral resolution is nonlinear, being approximately 1 nm in the blue and 7 nm in the red. A prototype of this instrument is currently being built at DOE's Pacific Northwest Laboratory (PNL) and should be completed in early 1990. Characterization of the out-of-band rejection and spectral alignment will be the initial requirements.

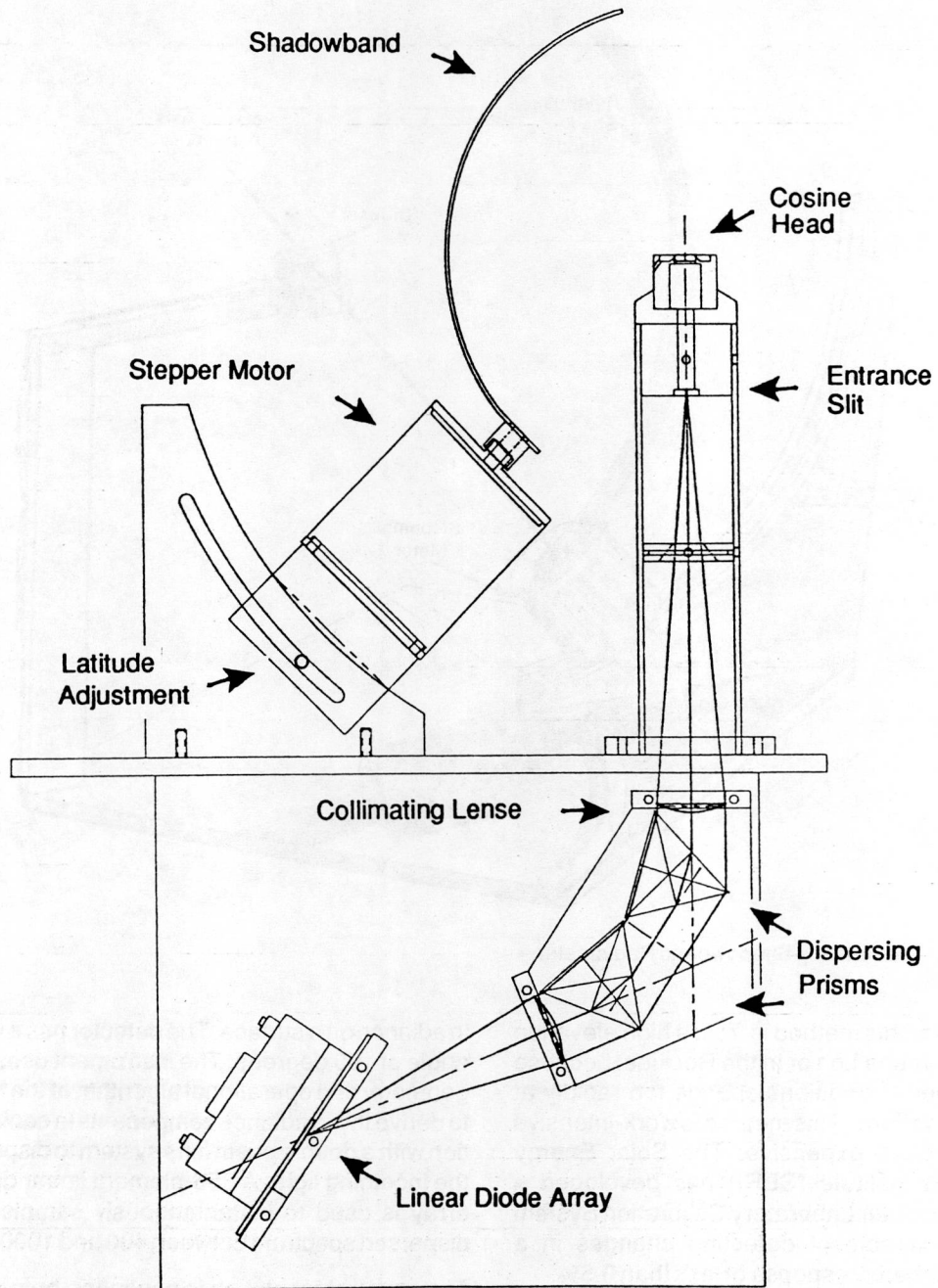

Figure 23. The Rotating Shadowband Spectrometer.

An absolute calibration against a spectral lamp will be needed on a semiannual basis. A serious consideration for this instrument will be massive amounts of digitized data it can produce.

Spectroradiometers

Commercially available spectroradiometers are designed to obtain spectrally resolved measurements of shortwave radiation. The instruments are often portable and designed for field measurements.

Wavelength resolution is achieved using a grating monochromator with a spectral scanning range of 300 nm to 1100 nm and with a typical maximum resolution of 6 nm. The field of view is 180 degrees. Attachments are available to limit the field of view. The scan time is approximately one minute. The light leaving the monochromator is sampled by a silicon detector. An internal computer handles all the data collection, storage, and communications.

SERI has made extensive studies of these instruments' accuracy (Riordan et al. 1989). There is loss of accuracy longward of 1000 nm because the detector is not temperature controlled and the signal-to-noise ratio is poor below 400 nm. Between 400 and 1000 nm the accuracy is better than 8%. The manufacturer recommends recalibration semiannually using a spectral lamp source.

Generally, the user must manually point the instrument at the desired scan target and use a 'dumb' terminal to set up and take the scan. The instrument has some limited capabilities for automatically scanning at uniform time intervals.

Longwave Instrumentation

Longwave measurements are generally used for two purposes: 1) to characterize the thermal emission from the atmosphere, and 2) to measure the integrated column density of atmospheric constituents using the sun as a background source. Under properly controlled circumstances atmospheric absorption at the

surface can also be measured using a black-body background source.

Broad-Band Instruments

Precision Infrared Radiometer

Broad-band longwave radiation can be measured by a Precision Infrared Radiometer (PIR). This instrument has a 180-degree field-of-view and measures the longwave radiation arriving at a surface. The spectral response is 4 mm to 50 mm. The instrument is calibrated with a black-body emission source semiannually. The manufacturer claims the instrument's accuracy is 2%, but intercomparison studies indicate relative accuracy is closer to 10%. The instrument is designed for continuous measurement producing a millivolt signal output. This signal must be digitized and logged by a separate data collection system.

Spectral Instruments

In the infrared there are two classes of spectrometer which are candidates for ARM systems: interferometers and grating instruments.

Interferometry

The operation of a Fourier transform interferometer is relatively simple in concept, while the practical operation of such a spectrometer can be quite demanding. As the name indicates an interferometer uses the principle of interference of electromagnetic waves to generate a spectrum.

The general operation of a Fourier Transform Spectrometer (FTS) can be described as follows. After electromagnetic radiation enters the device, it is first collimated and made into a beam in which all of the waves are parallel. This collimated beam next encounters a beam splitter. The beam splitter can be thought of as an optical flat oriented at 45 degrees to the entering beam, although a wide variety of geometrical configurations are possible. The beam splitter is coated with a dielectric coating (in the infrared this is generally KCl or KBr) which causes

approximately half of the beam to be transmitted through the beam splitter and half of the beam to be reflected. With the two beams separated this way, the spectrometer directs the two beams along different optical paths. These two beams are then brought back together before entering a detector.

The interference is created by causing the different paths of the two beams to go through different path lengths before recombination. By varying the path difference between the two beams one creates the fourier transform of the original spectrum. The resolution of the spectrum is determined by the total path difference over which the two paths are varied and the precision with which the path difference can be controlled.

Grating Spectrometers

Grating spectrometers operate in the infrared using the same basic principles as spectrometers operating in the visible portion of the spectrum. Generally speaking grating instruments are capable of making the same observations as interferometers. Grating instruments cannot match the high spectral resolution of the Fourier transform instruments and the finite scan time for the instruments usually leads to their application for relatively limited spectral intervals. One advantage of a grating spectrometer relates to the problem of calibration. Grating spectrometers give a true radiometric zero; and grating errors at different wavelengths are independent, whereas errors in an interferometer propagate to all wavelengths because of the properties of the Fourier transform. However, recent developments in Fourier transform spectroscopy have improved greatly the calibration of interferometers.

Meteorological Instrumentation

Within the context of this plan, "meteorological instrumentation" is defined as measurement equipment, aside from direct radiation detection devices, which pertains to the dynamic and thermodynamic states of the atmosphere. For

the reasons of area coverage and time-response discussed above, remote-sensing techniques are usually the primary methods of choice for meteorological measurements in ARM. However, measurement uncertainties and information gaps necessitate supplemental measurement techniques. Therefore, fixed and moving point sensors will be incorporated as well.

A discussion of meteorological instrumentation is provided in the following four subsections. First, the basic remote-sensing meteorological technologies are described followed by a description of an example system, employed at NOAA's Wave Propagation Laboratory (WPL), which incorporates these technologies. The third subsection discusses supplementary instrumentation from moving point sensors. Last, an outline is provided of instrumentation used for surface property measurements.

Surface-Based Remote Sensing Instrumentation: Systems Overview

Tremendous progress has been achieved over the last two decades in the development of sophisticated remote sensing systems. Some of the desired measurements can be obtained using automated, unattended equipment operating on a routine basis. Active and passive optical, radio, and acoustic techniques are used to interrogate the atmosphere. Combinations of different remote sensors yield more useful information than could be derived from individual systems. Data sets which merge remote sensing and in situ measurements are enriched by the strengths of both approaches.

Passive remote sensors measure signals that are naturally emitted by atmospheric constituents. Microwave radiometers and cameras are examples. Active remote sensors transmit energy which interacts with the atmosphere in a manner that returns a signal containing information about the interaction and, therefore, the atmosphere. Radars, lidars and sodars are active systems which employ radio, optical and

acoustical waves, respectively. By strategic choices of wavelengths, a great variety of atmospheric information can be obtained from basically similar techniques. Table 4 lists the parameters which can be measured by various remote sensors.

Table 4. Measurable meteorological parameters from remote sensing systems.

| | |
|------------------------|--|
| Doppler Radar - | location and intensity of precip. and some clouds, wind profiles and 3D patterns, turbulence parameters, inferences of particle shape from dual polarizations |
| Doppler Lidar - | location and loading of aerosols, presence of clouds, wind profiles and 3D patterns, turbulence parameters, water vapor and ozone concentrations and fluxes, particle shape and water phase inferences |
| Microwave - Radiometer | temperature profiles, path-integrated water vapor and liquid water content, directional distributions of water vapor and liquid |
| Wind Profiler - | profiles of wind (u, v, w components), drop size distribution in warm clouds and rain |
| RASS - | profiles of virtual temperature |
| Doppler Sodar - | turbulence parameters, inversion height, boundary layer mixing, wind profiles |

Radar

Meteorological radars are the most mature of the remote sensing technologies. Conventional radar units use mechanically rotated antennae and employ wavelengths ranging between about 0.8 and 11 cm, although special-purpose devices have wavelengths extending significantly above and below these limits. The most common scattering targets for conventional radars are precipitation particles (diameter $>100 \mu\text{m}$). Large droplets and ice crystals in nonprecipitating clouds also can be detected by sensitive radars, particularly those operating in the lower

wavelength regions. When scanned, a radar can produce a three-dimensional map of the location and intensity of precipitation, and detect the presence of some nonprecipitating clouds. Sensitive radars will also receive strong signals backscattered from refractive index inhomogeneities, insects, and very large dust particles in the visually clear atmosphere. Millimeter-band radars, currently under development, show high promise for measurement of specific cloud-physical properties.

In addition to the above capabilities, Doppler radars also measure the radial component of velocity of the scattering targets. When measurements from two or more separated Doppler radars are combined, the three-dimensional wind field in the precipitation area can be mapped. Wind speed accuracies of 0.5 to 1.0 cm/s are typical. A single Doppler radar can obtain vertical profiles of the horizontal wind vector with an accuracy better than 10 cm/sec when scanned at constant elevation angle. This is known as the Velocity Azimuth Display (VAD) method. A very accurate estimate of the vertical component of motion is obtained by pointing the radar at the zenith. The technique when applied in the clear convective boundary layer yields turbulence quantities.

Radar beam widths are typically 1 degree. Maximum ranges are typically about 50 to 100 km with range resolution of about 100 m. Scan rates and data sampling are rapid enough to sweep out a significant fraction of the entire sky volume with good angular resolution in less than 5 minutes. Only the most intense rain or hailstorms will attenuate the radar waves enough to block the beam. The radar beam does include significant energy in side lobes which often causes ground clutter contamination of low elevation scans.

Lidar

Lidar sensing devices use lasers to transmit highly collimated beams of light that interact with gaseous and aerosol constituents of the atmosphere by scattering and by direct absorption. In different configurations these units can measure temperature and wind speed as well as chemical

composition. Lidar wavelengths usually fall in the visible to infrared range and are chosen to optimize backscattering from aerosols or to match a molecular spectral line. Lidar systems have maximum ranges of about 20 km. Typical beam widths are about 1 milliradian and the range resolution is about 100 m. Lidar measurements do not suffer from ground clutter problems, but the beam is strongly attenuated by cloud droplets and generally cannot probe beyond the nearest water cloud or rainshower in a given direction. Lidar technology can be applied in various configurations for the remote sensing of temperature, wind fields, water vapor, and cloud structure. These will be discussed sequentially in the following text.

Temperature can be measured by several lidar techniques, some of which are discussed by Schwiesow (1983). These are all based upon the scattering and absorption characteristics of molecules in the atmosphere that are, in turn, dependent upon temperature, and are summarized below.

- Raman Scattering - The population of the energy levels of the rotational Raman scattering spectrum is determined by the temperature of the molecules. Thus the ratio of Raman lidar measurements at several different levels within a rotational band can be used to infer the temperature, since the relative populations will change in a known fashion with temperature. Another option is to determine the density profile through measurement of the Raman vibrational scattering by nitrogen. In this case it is necessary to assume a pressure distribution in order to calculate the temperature. As with all Raman scattering measurements, the signal is weak and measurements usually must be performed at night in order to avoid the increase in noise due to the effects of direct sunlight. Reported measurements generally have vertical resolution of about 100 m or less and require about 5 minutes of averaging time.
- Rayleigh Scattering - The Doppler broadening of a molecular scattering linewidth is determined by the molecular motion, which is in turn determined by the temperature and

described by Maxwell-Boltzmann statistics. Thus interferometer measurements of the linewidths, produced by scattering with a pulsed lidar of the appropriate frequency, can be used to determine the temperature profile. Schwiesow (1983) and Schwiesow and Lading (1981) indicate that a system can be developed to measure temperature to 5 km, with 50-m resolution to within 1K. Below 3 km, Brillouin scattering affects the linewidth measurement and must be accounted for. As with many lidar systems, penetration through clouds is virtually impossible.

- Differential Absorption Lidar (DIAL) - DIAL is the leading candidate for lidar temperature determination. DIAL operates by using two lasers, one tuned to a specific, strongly temperature-dependent absorption line peak, and another whose wavelength is shifted a small amount from that line to minimize molecular absorption. Pulses are generated at the two laser wavelengths within a time interval that is short compared to the time scale of atmospheric dynamics, i.e., $<100 \mu\text{s}$. The two laser pulses are backscattered to the receiver telescope by atmospheric aerosols and molecules and are detected as a function of the range probed. Thus, the return signals represent a time history of the scattering and absorption properties of the atmosphere for each layer-pulse pair, and can be related to a spatial profile of these properties from which the temperature profile can be determined.

This technique has been developed sufficiently to estimate operating parameters, based upon use of a 100-mJ, 10-Hz tunable laser that lead to 1°C accuracies with 150-m resolution for 1 to 4 minute observation times up to about 4 km. Tradeoffs among the variables can extend the probe range significantly. Tunable solid-state lasers (Ti:sapphire and alexandrite) are the sources of choice for this method.

Wind field measurements made with lidar are usually based on a Doppler technique that operates in a fashion that is analagous to Doppler radar. Being characterized by much higher frequencies, they are sensitive to different atmospheric constituents, e.g. aerosols, than

radars are. The Doppler lidars used are usually the Ruby ($0.7 \mu\text{m}$) lidar or the CO_2 ($10.6 \mu\text{m}$) lidar, which is eye safe. Since the Doppler shift is proportional to the frequency, the Ruby lidar is more sensitive to wind-speed differences ($\sim 0.3 \text{ m/s}$ radial). The lidar beamwidth is generally considerably less than 1 degree; thus radial velocity measurements are not likely to be contaminated by motions perpendicular to the beam. The range of these instruments is roughly 5 to 10 km or more, depending upon signal sources and laser strength. However, penetration of clouds is not possible with ruby lidar systems.

Non-Doppler measurements of the horizontal wind field with lidars have been made that avoid the spatial sampling problems of poly-monostatic operation. Sroga et al. (1980) used a Ruby lidar to map velocities in a 1-km by 100-m resolution cell. This technique potentially allows a complete three-dimensional mapping of the horizontal wind field up to 5 km or more using high repetition and data rates that are now possible. However, when the atmosphere becomes well mixed, it is more difficult to distinguish between structures, even though signal strengths are large, and velocity determination is more difficult. This type of operation has not been shown to be successful at night. Time-of-flight techniques are described by Schwiesow (1983) wherein the time for a particle to traverse between two laser beams is determined by the time between returns from the two locations. Combining two measurements of this type in orthogonal planes and a Doppler radial measurement potentially gives the three components of the wind field at one location.

For general use, including the capability to probe long ranges, DIAL (a technique based upon absorption of a water vapor spectral line) will be the technique of choice. High spatial resolution and species specificity can be archived by using pulsed laser radiation backscattered at wavelengths 1) on a water-vapor absorption line peak and 2) far in the line wing, from two ranges separated by a length dz , in such a fashion as to perform an attenuation measurement over the designated remote atmospheric sample of length dz . Alternatively, columnar water vapor concen-

trations can be obtained in this way if only one range is employed. In order to achieve the simultaneous determination of both backscattered signals, two lasers are advantageous.

Water-vapor concentration can be measured with lidar using either DIAL or Raman backscattering techniques. Various laser sources are possible for use in water-vapor DIAL. These include tunable solid-state lasers such as alexandrite and Ti:sapphire, Nd:YAG-pumped tunable dye lasers, and CO_2 lasers, for which spectral coincidences exist with accessible water-vapor lines. Each of these sources possess specific merits (such as the thorough knowledge of water-vapor absorption coefficients in the CO_2 laser spectral zone). The overall trend of development of the tunable solid-state laser sources suggests that these will become the best choice for water-vapor measurements. They are capable of data acquisition over a wide range of altitudes with the potential for hardening into an automated system. A detailed analysis of a solid-state, laser-based, water-vapor DIAL system indicates that vertical and horizontal resolutions of 200 m and 10 km, respectively, can be achieved for water-vapor profiles during nighttime with $<10\%$ measurement accuracy. For daytime, these numbers become 300 m and 20 km.

Raman-scattering lidar water-vapor profiling is based upon the inelastically-shifted backscatter signal resulting from the specific vibrational-rotational internal structure of the water-vapor molecule. Although the cross section for this process is very small, determinations of the water-vapor mixing ratio in the lower atmosphere have improved greatly. The most recent data have been acquired using a frequency-tripled Nd:YAG laser at 355 nm, in order to exploit the strongly enhanced cross section as one progresses toward the UV. Data are collected for the Raman water-vapor signal at 408 nm, the Raman nitrogen signal at 387 nm (used for calibration), and the elastic Rayleigh and aerosol scattering at the laser wavelength. Because of the weakness of the Raman return, 1000 laser pulses are usually required (over a two-minute interval) to obtain significant data.

Darkness is required in the present state of development, although a daylight system will likely be operational by mid-1991.

A useful recent comparison of DIAL and Raman lidar indicates, generally, that both permit coverage of the lower troposphere for water-vapor determinations to <5% accuracy, with typical altitude resolutions of 50 to 150 m. However, DIAL has an inherent advantage for long-range data acquisition.

Cloud structure and morphology can be measured with lidar as well. However, the general opacity of clouds to light in the visible/IR spectrum limit the potential of these measurements. Cloud structures that can be measured with lidar include the geometric shapes of clouds (in regions where the cloud boundaries are visible to the lidar) and the ice/water phase mix within the clouds.

Microwave and Infrared Radiometers

Passive microwave and infrared radiometers measure the radiation coming from a narrowly defined portion of the sky to determine temperature, water-vapor, and liquid-water content (Decker et al. 1978). Used primarily in satellite measurements of temperature, the method is also incorporated into ground based remote-sensing schemes.

Measurements of radiation in a selected number of narrow bandwidths (channels) are made simultaneously in the absorption band of oxygen. The amount of radiation in a given channel at each height is temperature dependent (depending upon the population of that energy state). Each measurement is the result of the path integrated radiation through the atmosphere. Thus the problem is to invert the integrated measurements to retrieve the temperature and moisture content. A model of the path weighting for each channel is used along with statistical knowledge of the known temperature patterns and a first guess at the temperature profile in order to perform the inversion.

Operational microwave-radiometry temperature profiling has coarse altitude resolution (about 100 mb increments). Therefore, it is difficult to detect small-scale temperature features such as elevated inversions. However, promising improvements have been demonstrated by combining the surface-based radiometer temperature data and measurements from satellites or with radio acoustic sounding systems (see RASS below).

Although range resolutions are coarse, microwave radiometers provide path-integrated quantities of parameters such as geopotential height, and water-vapor with accuracies comparable to radiosondes. The temperature, water-vapor, and liquid-water data are collected continuously and unattended with time resolution of about 2 minutes. This provides excellent records of temporal changes over a site. Although the water-vapor and liquid water measurements are totals, integrated along the entire beam path, angular scanning provides distribution maps which can be applied to infer distributional behavior. This is the best operational remote sensing system for unambiguous detection of the presence of liquid water in clouds.

The High-resolution Interferometer Sounder (HIS) is an infrared radiometer system under development for eventual deployment on satellites. Tests from the ground indicate that the system shows promise for obtaining vertical profiles of temperature and humidity. It operates at wavelengths between 4 and 17 μm and makes the equivalent of about 1600 high-spectral resolution radiation measurements in a few seconds.

Wind Profiler

Wind profilers (Hogg et al. 1983) are phased-array Doppler radars designed specifically to optimize detection of echoes from the refractive-index inhomogeneities of the clear air. An electronically steered beam measures the radial component of wind velocity in different pointing directions. From this information all three components of the wind vector are derived. In

general wind profilers consist of phased arrays with a varying number of sending elements. They operate in the monostatic mode (i.e. the receiver is colocated with the transmitters) with 3 to 5 beams, one vertically pointing and the others at about 75 degree elevation angle in orthogonal planes. The general operation consists of averaging, at each range gate, the phase of several (30 to 50) sequential pulses. The spectrum of these averages is then analyzed to determine the Doppler shift at each range gate. UHF (wavelengths of 33 and 75 cm) and VHF (6 m) have been used to measure winds over different height ranges and with varying height resolutions. The systems operate continuously and unattended in all weather conditions. A technique by which the profiler measures the velocity spectrum of falling rain and cloud drops shows promise for determining drop size in warm clouds and precipitation.

Advertized wind measurement accuracies for commercial equipment are from 0.9 m/s at low frequencies to 0.25 m/s at high frequencies for the radial component. In all cases, the maximum height, size and beamwidth is a function of the number of transmitter elements used, which is arbitrary. Minimum height is determined by the pulse length used. Longer pulse lengths result in larger maximum and minimum heights. Nominally the minimum height is 150 m, but it may be as much as 1.5 km (6-m wavelength) or as little as 75 m (33-cm wavelength). The systems are increasingly sensitive to rain and cloud drops with increasing frequency, with little sensitivity in the 6-m system and significant sensitivity in the 33-cm system.

After more than a decade of development and research application, wind profilers have gained the acceptance and enthusiasm of operational meteorologists. A demonstration network of 31 profilers is now being deployed across the central United States. These systems use the 75-cm wavelength and provide hourly averages of wind profiles from 0.5 to 16 km above the ground in 0.25-km increments.

Radio Acoustic Sounding System (RASS)

By adding an appropriate acoustic source to a wind profiler system, the temperature profile of the lower atmosphere can be measured in addition to the wind profile (Marshall et al. 1972; Bonino 1984). These developing systems are called RASS for Radio Acoustic Sounding System. This system uses the radar to measure the upward progress of a pressure wave, which is emitted by an acoustic source and is matched to half the radar wavelength. Since the pressure wave's velocity is a function of the air's virtual temperature, this measurement, after correction for updraft speed and humidity, provides a direct indication of air temperature as a function of height. Accuracy of this technique is about 0.5°C.

The RASS process determines the acoustic-wave speed either from the Doppler shift of the scattered electromagnetic wave or by determining the acoustic frequency that satisfies the Bragg scattering condition,

$$2k_e = k_a$$

where k_e is the electromagnetic wave number, k_a is the acoustic wave number, and

$$\text{propagation speed} = 2\pi f/k_a.$$

The first Doppler method is utilized in most current applications. Since electromagnetic radiation travels at 10^8 times the speed of sound in air, necessary averaging can be accomplished, and vertical resolution comparable to that of the radar is easily obtained.

There are three principal problems with this method:

1. The vertical wind component, if not accounted for, appears as an error in temperature measurements. In convective conditions, near clouds, and in nonhomogeneous terrain this can be serious, particularly for short (less than 20 minutes) averaging times.

2. Loss of signal strength is caused by horizontal advection and turbulent deformation of the acoustic waveform. In strong wind conditions measurements have shown significant reduction in maximum height.
3. When moisture is present, the virtual temperature is derived from this process, rather than the actual temperature. Thus, moisture effects should be accounted for as a function of height. Often this effect is small. However, near clouds and near the ground it can be significant. Either some assumption must be made about the moisture distribution or measurements of moisture need to be incorporated into temperature retrievals.

The combination of a microwave profiler with an acoustic source has several advantages for this system. It is necessary for the profiler to use a different bandwidth to track the acoustic signal, but analysis techniques for the RASS are similar. A measurement of vertical velocity can be incorporated from profiler measurements to alleviate problem 1. The significant computational and averaging power inherent in profiler calculations permits signal definition in spite of many conditions associated with problem 2. Finally, the measurement of the three components of the wind are provided simultaneously. Potentially this can be used to correct for advection of the acoustic wave in a second generation system where, for example, the acoustic wave can be launched in a direction appropriate to counteract advective effects and so increase the maximum height. Given an alternate, accurate temperature measurement, it is conceivable that the moisture profile could be determined with the RASS technique.

The choice of acoustic frequency (and thus radar frequency) strongly affects the maximum height due to the rapidly increasing absorption of sound with frequency. A large array (approximately 10^4 m^2) of low frequency (50 Hz) acoustic sources has been used to determine temperatures to as high as the tropopause (Matuura et al. 1986) while mid-range frequencies with smaller sources usually attain 2 to 6 km. Figure 24 shows a schematic of the antenna plan

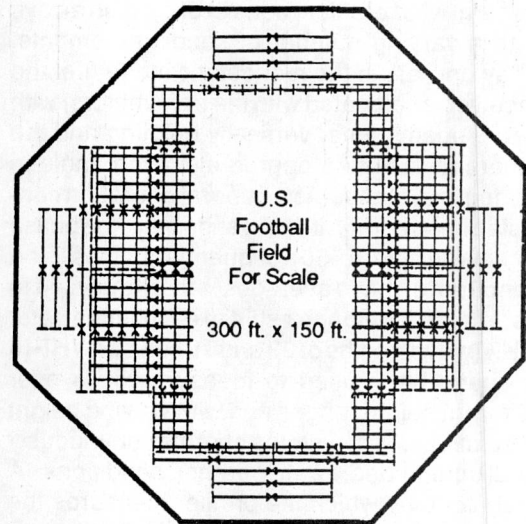

Figure 24. A large-scale RASS antenna array.

for such a large-array RASS system. Most reported accuracies are better than 0.5 K (Bonino et al. 1986). Vertical resolution, if used with profilers, is from 75 to 250 m or more, depending upon the sampling rate of the microwave profiler.

The RASS development has used various radar and acoustic systems to obtain temperature profiles over different height ridges. When combined with the 75-cm wind profiler, RASS provides temperature profiles up to about 3 km. The height resolution of the temperature data is the same as that for the winds, and time resolution of about 2 minutes is possible. Temperature measurements reaching the mid-troposphere have been obtained in research tests with a 6-m wavelength wind profiler.

Sodar

Sodars are acoustic sounders which provide information on the turbulence structure of the boundary layer. These are frequently used in air pollution studies to examine temporal changes of the height of inversion layers and the degree of mixing below. In Doppler configurations, they measure the wind-speed profile in the low atmosphere. The systems are relatively

simple and inexpensive and are available commercially.

Doppler sodars are available in monostatic (co-located transmitter and receiver) and bistatic (separated transmitter and receiver units) configurations. In the monostatic arrangement only the turbulent temperature structure contributes to the acoustic backscatter. In the bistatic geometry the acoustic signal is affected by small-scale velocity fluctuations as well as by temperature inhomogeneities. The acoustic frequencies used in these devices is typically about 2 kHz. Wind profiles and turbulence-structure information up to about 500 m are usually possible. Microsodar systems which use higher frequencies (5 kHz) and lighter antennas provide data from about 10 to 100 m above the ground. Low frequency phased-array sodars have been used to reach larger heights since sound absorption decreases significantly with decreasing frequency.

Camera Arrays and Cloud Morphology Studies

The flux of incoming solar radiation at the surface can be influenced not only by the fraction of cloud cover, but also by the cloud characteristics. In the tropics, for example, solar radiative flux often reaches a maximum value shortly after the onset of cumulus convection in the late morning hours. Diffuse radiation due to solar reflectance off cloud surfaces, combined with direct flux, can result in total flux levels that may exceed the solar constant when the measuring site is not in cloud shadow. Furthermore the apparent regional cloudiness may not be represented properly when determined from a single point because of the misperceptions that result from viewing distant clouds. An important feature of the ARM Program Plan is to establish a surface-based cloud imaging system at the research sites that will provide the appropriate information for parameterizing this influence of cloud cover on solar flux over an entire grid cell.

In a recent review of cloud imaging technology over the whole-sky dome, McGuffie and

Henderson-Sellers (1989) trace the history of efforts to capture cloud images on a two-dimensional film surface based on considerations that the sky actually represents a three-dimensional inverted sphere. For whole-sky imagery, three basic techniques are discussed: refraction systems, reflection systems, and moving film systems:

- Refraction systems have been in use since 1911. A common application is the "fish-eye" lens mounted on a standard 35 mm camera. However, in order to capture the whole sky, refraction systems produce "gnomonic" images, which are increasingly distorted toward the edges. This distortion may be inappropriate for quantifying the radiative characteristics of clouds at a point.
- Reflective systems consist of cameras mounted over a spherical reflection device. These systems are simpler to operate, and the exact nature of the distortion can be controlled by the shape of the reflecting surface. A drawback to these systems is that the reflected image is very sensitive to the position of the camera over the reflector.
- Moving film systems have not been given widespread application. Only one reference to this approach, dating back to 1915, is mentioned.

Recent uses of all-sky camera systems may be relevant to the ARM experiment. MacArthur and Hay (1979) determined that all-sky photographic images of clouds can be used to quantify diffuse incoming solar radiation. Extensive work has been undertaken by Holle and his colleagues (e.g., Holle and MacKay 1975). Their studies established schemes, using both refractive and reflective systems, to produce azimuthally equidistant projections. They also used techniques to account for the fact that clouds of equal dimensions can appear to be covering a different surface area when viewed from a distance. References are also given on recent uses of fish-eye lenses to quantify the "view factor" in complex radiative environments. McGuffie and Henderson-Sellers also cite recent advances in

cloud cover measurements using computer-operated whole-sky systems for computing cloud height, speed, and direction of movement based on triangulation methods.

The McGuffie and Henderson-Sellers paper summarizes many considerations that are of direct relevance to applications for ARM, such as projection characteristics of lenses, comparison of satellite with surface observed images, and film and filter characteristics. These points require careful review within the ARM prior to field implementation of a system. An ideal configuration for ARM would involve one or more remotely-operated camera systems where the images can be readily digitized, and supplemented by routine satellite imagery, so that reflective properties as well as regional distributions of clouds can be accurately characterized for model parameterizations.

Example of Surface-Based Remote Sensing Systems

The NOAA Wave Propagation Laboratory (WPL) in Boulder, Colorado, has pioneered many of the remote sensing techniques in use today. Over the last 22 years, WPL engineers and scientists have conceived, developed, and field tested a variety of instruments and have utilized them in basic atmospheric research. Although systems with similar or different capabilities are also in use at other institutions, WPL probably has the largest number and most diverse collection of ground-based remote sensing systems in the United States. Table 5 lists remote sensing systems that are currently in use at WPL and that could be available to the ARM Program. Included in the list is the Boulder Atmospheric Observatory (BAO) tower facility, which provides in situ measurements of several meteorological parameters and is frequently used for comparisons with the remote sensing measurements.

Table 5. NOAA Wave Propagation Laboratory remote sensing facilities.

Radars - two X-band (3.2 cm) Doppler scanning, dual-polariz; one K-band (0.8 cm) Doppler, scanning, dual-polariz

Lidars - ruby (visible) dual-polarization, scanning

Radiometers - one, six channel continuous operation at Stapleton; one, two channel continuous operation at Platteville; one, three channel, transportable, scanning; two, infrared for cloud base temperature

Wind Profilers - UHF (33 cm) at Stapleton Airport, 3 modes: 0.4 - 24 km, 1.6 - 24 km, or 2.7 - 18 km VHF (6 m) at Platteville, CO; 2 modes: 1.8 - 22 km or 3.0 - 18 km, UHF (75 cm) transportable, 0.4 - 7.0 km; UHF (33 cm) boundary layer, transportable, 0.1 - 1.5 km

RASS - combined with Stapleton, Platteville or transportable wind profilers to give temperature profiles in ranges of 0.2 - 1.5 km, 2 - 9 km, and 0.4 - 2.5 km, respectively

Sodars - three bi-static systems for boundary layer turbulence and wind profiling to about 500 m, one micro system for wind in lowest 100 m

BAO Tower - 300 m tall; fixed instruments at 10, 50, 100, 150, 200, 250 and 300 m; rapid response measurement of temperature, dew point, wind speed, wind direction and solar radiation. Pressure measured at surface. Carriage platform can lift instrument packages to any intermediate level or can be used to obtain slow 0-300 m profiles with instrument packages.

Moving Point Sensors Radiosondes and Other Free-Flying Balloon Systems

Measurements of this class are relatively straightforward. Balloons are used as a vehicle to carry a lightweight sensor package, and are tracked

either visually or by some remote-sensing device such as radar or LORAN. Wind speed is observed by the tracking system, while other data (typically altitude, temperature, and humidity measurements) are obtained by radio transmission. In most, temperature is measured using thermistors. Since these sensing elements require an electric current for operation, heat must be dissipated from around the element in order to measure the true air temperature. This is accomplished either by blowing air across the element with a small fan, or by aerodynamically forcing air across the thermistor as the package passes through the air, in the case of free-flying sondes.

The size of the thermistor determines the time response of the temperature measurement: larger thermistors have longer time constants but are more rugged. Time constants range from 0.1 s to 20 s or more. Thermistors vary somewhat from one to another, therefore they are not attractive for difference measurements. In this case, thermocouples are more appropriate.

Humidity is typically measured using a carbon-substrate sensing element, having an accuracy of roughly 5 to 7% under most conditions, although corrections for time-response are mandatory to obtain this accuracy.

Tethered Balloons

A significant problem associated with balloon borne profiles is that they provide only a "snapshot" of the temperature profile, rather than an average value. Even then the data from different heights is not simultaneous, but determined by the rise rate of the balloon. Tethered balloons can provide average values by remaining stationary at successive positions, but the time difference between heights increases significantly. Tethered balloon measurements rarely exceed 1 km, except with very large balloons. Free-flying balloons can penetrate to very great heights, if desired.

In the case of tethered balloons, the wind speed is generally measured with a cup anemometer,

although any number of methods can be used, including propellers, sonic anemometers, hot-wire anemometers and films, etc. The accuracy of these wind measurements is limited due to the deformation of airflow around the balloon and are sensitive to the motion of the balloon and the resultant motion of the package attached below the balloon. Thus, the tethered balloon must either rise very slowly (less than 0.5 m/s), or stop at selected intervals. Wind direction is often determined by the pointing direction of the balloon, if it points into the wind and the package points at a constant angle relative to the balloon. Otherwise, a vane must be used or separate components measured. Measurement of vertical velocities is rarely attempted on a tethered balloon operation unless the balloon is very large and the platform is stable and suspended well below the balloon, in which case it does little profiling.

Cloud Physics Sampling by Aircraft

Over the past 10 years optical probes, including optical sizing and two-dimensional array imaging, have contributed strongly to advances in the aircraft measurement of clouds, aerosols, and precipitation. These probes are typically located external to the aircraft, and are electronically controlled and monitored by onboard devices. Probes of different optical configurations are used to count and size particles ranging from sub-micron aerosol size up to particles having the dimensions of large raindrops. Two-dimensional imaging probes provide additional information on surface area and, to a limited extent, crystal morphology. Major advantages of the newer optical instruments include their ease of data processing and analysis, and the robust statistics provided by the associated high particle counts. As indicated in Table 6, spectra obtained from optical probes can be integrated to provide secondary measures of condensed water content.

Alternative methods for ice-particle distributions and morphology include Formvar replicators and foil impactors. While these techniques generally

provide much more detailed morphological information than do optical probes, their associated data processing is exceedingly labor intensive and cumbersome. Because of this disadvantage, these devices are not recommended for extensive deployment in ARM.

Secondary techniques in Table 6 have been flagged according to their advisability for use in ARM, as indicated by the footnote. Of these, categories (1) and (2) are sufficiently important and easy to perform that they are recommended for extensive deployment in the ARM Program. Cloud-condensation nucleus (CCN) counting is important as well, but current counting technology is sufficiently ambiguous and cumbersome to place this measurement only in intensive

campaign efforts. Presently the most proficient cloud-condensation nucleus counters are custom devices, which are resident at the research organizations where they were designed and constructed. Highly skilled personnel are required to generate meaningful results with these devices.

Aerosol chemical content is an important consideration in determining a particle's activity as a cloud and/or ice nucleation site. This measurement requires collection with subsequent laboratory analysis; and since chemical composition varies with particle size, a size-segregated sampling device, such as a low-pressure impactor is required. Since this measurement process is expensive, it should only be deployed as

Table 6. Summary of key cloud-microphysics measurements.

Part I: Primary Measurements

| Quantity Measured | Candidate Techniques |
|--------------------------------------|--|
| liquid water content | heated wire, integrated size spectrum (see below), virtual impactor (see Part II, below) |
| solid water content | integrated size spectrum (see below), virtual impactor (see Part II, below) |
| cloud-droplet size distribution | optical probe |
| raindrop size distribution | optical probe |
| ice morphology and size distribution | optical array probe, Formvar replicator, foil impactor |

*Part II: Secondary Measurements**

| Quantity Measured | Candidate Techniques |
|---|---|
| thermodynamic properties: temperature, pressure, humidity (1) | standard research aircraft package: resistance thermometer, piezoelectric transducer, mirror hygrometer |
| aerosol loading and size distribution (2) | optical probe, optical particle counter, electrostatic mobility analyzer |
| cloud condensation nucleus count (3) | controlled humidity chamber-optical counting device |
| ice nucleus count (4) | controlled supercooled chamber device |
| aerosol chemical content (3) | low-pressure impactor |
| cloud-water chemical content (3) | counterflow virtual impactor |

*Flagging convention for secondary measurements is as follows: (1) important and easy to perform; (2) important but moderately difficult or expensive to perform well; (3) important but very difficult to perform well; (4) relatively unimportant. Categories (1) and (2) are recommended for routine application; category (3) is recommended for intensive campaigns, as deemed advisable to specific campaign objectives.

required on special campaigns. This is true also for the chemical content of cloud water, which may be measured unambiguously using a relatively new technique, known as cloud-water virtual impaction. Cloud-water virtual impactors are not available commercially, they must be custom built.

A major disadvantage of aircraft sampling platforms is their characteristic of providing one-dimensional lines of data along a flight track, rather than automatically and rapidly sweeping out a total three-dimensional volume. In practice this is compensated by flying multiple tracks throughout the volume and by deploying multiple aircraft. Computerized techniques for designing flight patterns to optimize three-dimensional data capture have been developed within DOE.

Measurement Instruments for Surface Properties and Surface Fluxes

Reflected Radiation Instrumentation

Net surface radiative forcing requires measurements of reflected short and long wavelength radiation from the surface of the earth. It is necessary that the measurements have spectral resolution. High fidelity spectral resolution can be achieved with a grating spectrometer; however, such measurements can be acquired spectrally with high resolution diode arrays, which can have spectral resolution to 1 nm. The diodes have sensitivity from near UV to near IR, have a dynamic range of over 6 orders of magnitude, are relatively inexpensive, require no moving parts, require little power, and can be intercalibrated to absolute relative accuracy using a light source traceable to an NBS standard source. In the field the diodes can be checked for wavelength accuracy on an automatic, routine basis with a low powered Ar or Ne laser source.

Diode arrays do not extend to the far IR. Three other detectors are attractive for such measurements: silicon photodiodes, Ge photodiodes and pyroelectric detectors. Si photodiodes are sensitive from 190 to 1100 nm, peaking at 950 nm, with an output of 0.5 A/W and a noise equivalent power (NEP) of 2×10^{-14} W/Hz^{0.5}. Ge photodiodes extend from 700 to 1900 nm, with a sensitivity of 0.7 A/W and a NEP of 1×10^{-12} W/Hz^{0.5}. Pyroelectric IR detectors extend from 1,000 to 15,000 nm with a sensitivity of 2 to 4 kV/W, but a NEP of only 5×10^{-10} W/Hz^{0.5}. All three devices require low power, are electronically stable and do not require HV power supplies or other special supporting circuitry. Moreover, they do not require Dewar cooling, as needed by the InAs, InSb or HgCdTe IR detectors. The Si and Ge photodiodes are characterized by higher S/N ratios compared with diode arrays, but are more difficult to calibrate. Nonetheless, for irradiance measurements above 1000 nm, they can be absolutely calibrated to an NBS source.

Measurements of reflectance spectra can be biased by fluorescence and luminescence artifacts. For example, all plants fluoresce in the red and far red (from 680 to 750 nm), and many minerals, such as uranium salts, fluoresce in the green. Fluorescence is the conversion of shorter wavelength light to longer wavelength resulting from the absorption and remission of light by molecules. Fluorescence emission will be seen by satellite images of the Earth's radiation field, but will not be seen by upward looking spectrometers. Thus, an apparent discrepancy between the radiative measurements could be due to physical phenomena on the surface. These phenomena could be identified from reflectance spectra.

Latent and Sensible Heat Flux

The measurement of latent heat flux, which corresponds to water vapor flux density, above the surface of the earth has been the subject of study for many decades (Brutsaert 1982). The techniques and instruments are described in

many places (e.g., Fritschen and Gay 1979; Kanemasu et al. 1979). For long-term operation, the energy-balance Bowen ratio (EBBR) method provides one viable technique (e.g., Rosenberg et al. 1983) and has been used extensively for the First ISLSCP Field Experiment (Sellers et al. 1988).

At least two commercial sources exist of instrumentation packages to carry out EBBR measurements, which include net radiation, gradients of temperature and humidity, soil temperature, and soil heat flux. To carry out the entire analysis, separate measurements of soil moisture are required along with an evaluation of soil heat conductivity as a function of soil moisture. When properly employed, EBBR estimates of latent heat flux have typical uncertainties of $\pm 15\%$, or 30 W/m^2 , whichever is larger, and the corresponding estimates of sensible heat flux are $\pm 10\%$, or $\pm 20 \text{ W/m}^2$.

Estimates of latent and sensible heat flux by the EBBR method over deep forest canopies are generally considered more difficult and less reliable than over relatively short canopies, such as agricultural crops where the EEBR technique has been applied most frequently. Difficulty is increased by the fact that a tall tower is required to place the instruments over the vegetative canopy. The gradients of heat and moisture content are extremely small in comparison to those above short canopies. Also, the canopy heat storage is usually a much larger term for forests than for agricultural crops. Additional instrumentation is needed for sensing the bulk temperature of the major components (e.g., leaves, branches, boles) of the canopy.

The EBBR method is not considered as reliable for tall canopies because transfer coefficients for water vapor and heat across the vertical gradients are not always valid. One approach to overcoming this difficulty is to place the gradient measurement instruments at a considerable height above the canopy, but then proper inter-

pretation is difficult. The gradients to be measured become even smaller and therefore more difficult to measure with sufficient accuracy.

A better approach is to occasionally "benchmark" the EBBR results using the micrometeorological technique of eddy correlation (Kanemasu et al. 1979; Brutsaert 1982; Rosenberg et al. 1983). Eddy correlation is a more intensive and expensive approach than the EBBR method. Eddy correlation measurements can be taken on a routine basis with instruments that are available commercially. But implementation of this approach would require careful design by specialists who have developed this technique.

Surface Temperature

Surface temperature is presently measured most effectively with infrared thermometry (e.g., Miller 1981; Rosenberg et al. 1983). At least three commercial sources of infrared thermometers (bolometers) are available. An alternate approach is contact thermometry, usually with fine thermocouples, but measurement and deployment are very difficult over complex surfaces (e.g., vegetation).

Current bolometers typically have a precision of $\pm 0.1^\circ\text{C}$ and an accuracy of $\pm 0.5^\circ\text{C}$. New field instruments for long-term operation might have considerably better accuracy because of redesigned internal reference cavities. Generally, routine operation of bolometers for estimating surface temperature is within the state of the art. The uncertainty of the resulting estimates, however, is no better than the estimate of surface emissivity and the ability to estimate reflected infrared radiation. The effort to measure surface emissivity requires design of methods similar to those reported in the scientific literature, and remeasurement is needed whenever changes in surface characteristics are expected from a change in ambient temperature, soil moisture, etc.

Soil Moisture

The purpose of soil moisture measurements is to provide the required data to models and for measurement of the air-surface exchange of heat and moisture by the EBBR technique. For the latter, only local measurements are needed. For models, the objective is to model the latent and sensible heat fluxes, for which soil moisture is most important when water stress on actively growing vegetation limits transpiration.

There are many techniques to measure soil moisture content or potential. These include: soil psychrometry, neutron probe measurements,

gravimetric measurements of soil samples, and dielectric constant measurements. For a thorough evaluation and tracking of soil moisture content, a combination of several of these techniques is needed. Multiple sampling by each technique is usually required. Furthermore, because soil moisture content can vary by large amounts over distances of one kilometer or greater in regions where convective storms are common, multiple sampling locations might be necessary. Sampling of precipitation amounts should accompany the soil moisture measurements.

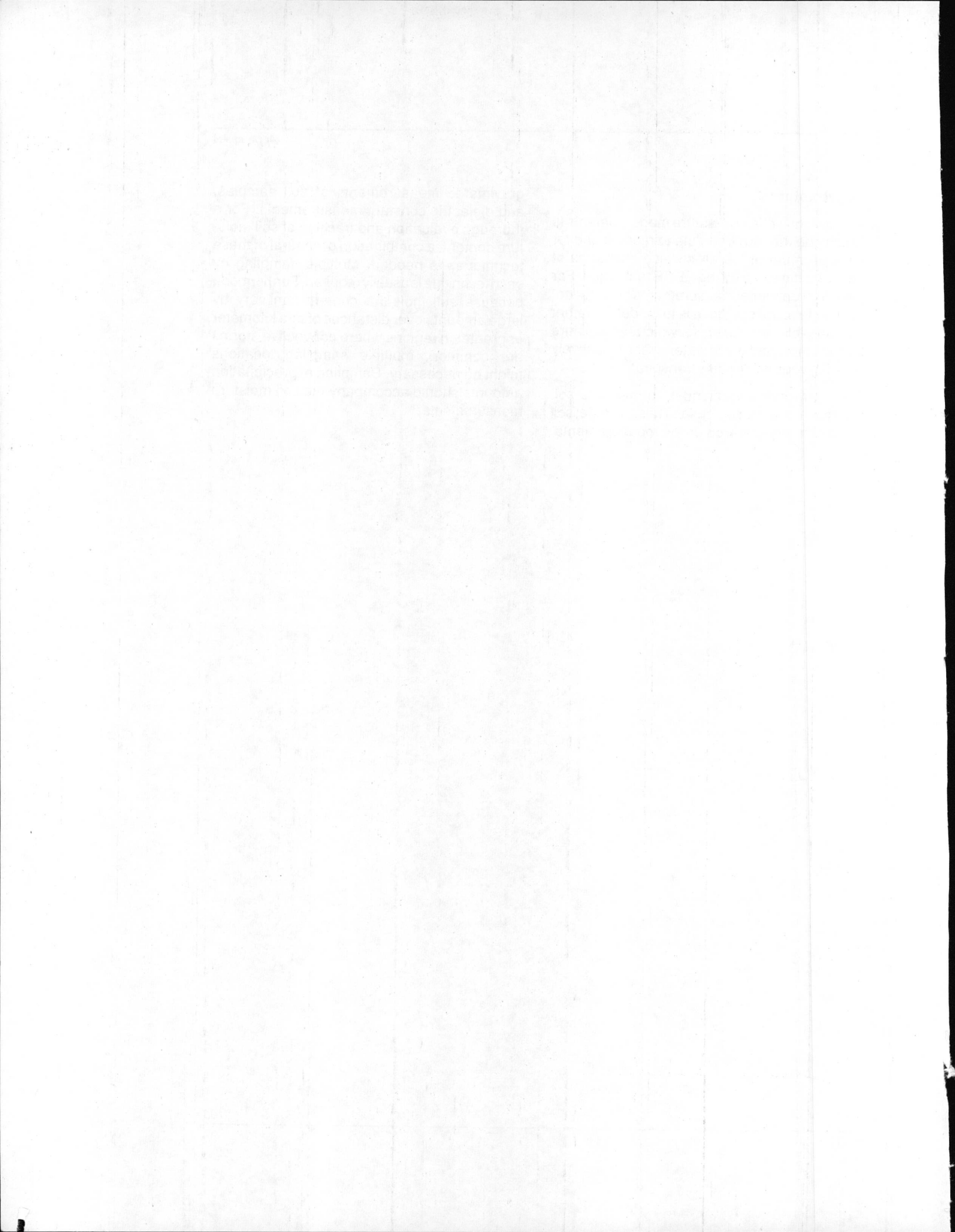

References

References

- Ackerman, S. A.**, and S. K. Cox. 1982. "The Saudi Arabian Heat Low: Aerosol Distributions and Thermo-Dynamic Structure." *Journal of Geophysic Research* 87:8991-9002.
- Albrecht, B.**, and S. K. Cox. 1977. "Procedures for Improving Pyrgometer Performance." *Journal of Applied Meteorology* 16:188-197.
- Allario, F.** 1988. Laser Focus/Electro-Optics pp. 65-74.
- Andraea, M. O.** 1985. "The Emission of Sulfur to the Remote Atmosphere." In *The Biogeochemical Cycling of Sulfur and Nitrogen in the Remote Atmosphere*, eds. J. N. Galloway, R. J. Charlson, M. O. Andraea, and H. Rodhe, pp. 5-25. Reidel, Dordrecht. D. Reidel Publishing Company, Dordrecht, Holland.
- Anthes, R. A.** 1977. "A Cumulus Parameterization Scheme Utilizing a One-Dimensional Cloud Model". *Monthly Weather Review* 105:270-286.
- Arakawa, A.**, and W. H. Schubert. 1974. "Interaction of a Cumulus Cloud Ensemble with the Large-Scale Environment". Part I. *J. Atmos. Sci.* 31:674-701.
- Ayers, G. P.**, et al. 1986. *Journal of Atmospheric Chemistry* 4:173-185.
- Barr, S.** 1987. "Deploy Measurement Systems to Meet Experimental Objectives." In *Proceedings of the American Meteorological Society*, 6th Symposium on Meteorological Observations and Instrumentation, January, New Orleans.
- Berry, E. X.**, and R. Reinhardt. 1974. "An Analysis of Cloud Drop Growth by Collection. Part IV, A New Parameterization." *Journal of Atmospheric Sciences* 31:2127-2135.
- Bonino, G.** 1984. "Remote Sensing of Thermal Profile in the Lower Atmosphere by Radio Acoustic System." In *Proceedings of the Second International Symposium on Acoustic Remote Sensing of the Atmosphere and Oceans*. XXXV:1-30, August 29 - September 1, 1983. Rome, Italy.
- Bonino, G.**, G. Elisei, A. Marzorati, and P. Trivero. 1986. "Test Results on Planetary Boundary Layer Sounding by Automatic RASS." *Journal of Atmospheric Research* 20:309-316.
- Brasunus, J. C.**, V. G. Kunde, and L. W. Herath. 1988. "Cryogenic Fourier Spectrometer for Measuring Trace Species in the Lower Stratosphere." *Appl. Opt.* 27:4964-4976.
- Browell, E. V.**, et al. 1986. "Development of a High-Altitude, Airborne DIAL System - The Lidar Atmospheric Sensing Experiment (LASE)." Thirteenth International Laser Radar Conference, August, 1986, Toronto. NASA Conference Publication 2431 (Abstracts).
- Brutsaert, W. H.** 1982. *Evaporation Into the Atmosphere: Theory, History and Application*. D. Reidel Publishing Company, Dordrecht, Holland.
- Burch, D.**, and R. Alt. 1984. *Continuum Absorption by H₂O in the 700-1200 and 2400-2800 cm⁻¹ Windows*. Report AFGL-TR-84-0128, Air Force Geophysics Laboratory, Hanscom AFB, Massachusetts.
- Cahen, C.**, et al. 1982. "Lidar Monitoring of Water Vapor Cycle in the Troposphere." *Journal of Applied Meteorology* 21:1506.
- Cess, R. D.**, and G. L. Potter. 1987. "Exploratory Studies of Cloud Radiative Forcing with a General Circulation Model." *Tellus* 39A:460-473.

- Cess, R. D., et al. 1989.** "Interpretation of Cloud-Climature Feedback as Produced by 14 Atmospheric General Circulation Models." *Science* 245:513-516.
- Chadwick, R. B.,** K. P. Moran, R. G. Strauch, G. E. Morrison, and W. C. Campbell. **1976b.** "Microwave Radar Measurements in the Clear Air." *Radio Sci.* 11:795-802.
- Chadwick, R. B.,** K. P. Moran, R. G. Strauch, G. E. Morrison, and W. C. Campbell. **1976a.** "A New Radar for Measuring Winds." *American Meteorological Society Bulletin* 57(9):1120-1125.
- Charlson, R. J.,** J. E. Lovelock, M. O. Andreae, and S. G. Warren. **1987.** "Oceanic Phytoplankton, Atmospheric Sulphur, Cloud Albedo and Climate." *Nature* 326:655-661.
- Charlson, R. J.,** J. E. Lovelock, M. O. Andreae, and S. G. Warren. **1989.** "Sulphate Aerosols and Climate." Scientific Correspondence, *Nature* 340:437-438.
- Clough, S. A.,** F. X. Kneizys, G. P. Anderson, E. P. Shettle, J. H. Chetwynd, L. W. Abreu, and L. A. Hall. **1989.** "FASCOD3: Spectral Simulation." In IRS '88: Current Problems in Atmospheric Radiation, eds. J. Lenoble and J. F. Geleyn, pp. 372-375. Deepak Publications, Hampton, Virginia.
- Cullis, C. F.,** and M. M. Hirschler. **1980.** "Atmospheric Sulphur: Natural and Man-Made Sources." *Atmospheric Environment* 14:1263-1278.
- Cutten, D. 1985.** "Atmospheric Broadband Transmission Measurements and Predictions in the 8-13 micron Window: Influence of Water Continuum Absorption Errors." *Appl. Opt.* 24:1085-1087.
- Decker, M. T.,** E. R. Westwater, and F. O. Guiraud. **1978.** "Experimental Evaluation of Ground-Based Microwave Radiometric Sensing of Atmospheric Temperature and Water Profiles." *Journal of Applied Meteorology* 17:1788-1795.
- Dignon, J.,** and S. Hameed. **1989.** "Global Emissions of Nitrogen and Sulfur Oxides From 1860 to 1980." *JAPCA.* 39:180-186.
- Durkee, P. A. 1989.** "Observations of Aerosol-Cloud Interaction in Satellite-Detected Visible and Near-Infrared Radiance." In *Proceedings of the American Meteorological Society Symposium on The role of Clouds in Atmospheric Chemistry and Global Climate*, pp. 157-160. January 30 - February 3, 1989, Anaheim, California.
- Eddy, A. 1974.** "An Approach to the Design of Meteorological Field Experiments." *Monthly Weather Review* 102:702-707.
- Edwards, D. P. 1989.** "Transmittance and Radiation Calculations: The Oxford Line-by-Line Model: GENLN2." In IRS '88: Current Problems in Atmospheric Radiation, eds. J. Lenoble and J. F. Geleyn, pp 408-411. Deepak Publications, Hampton, Virginia.
- Ellingson, R. 1982.** "A Note on Errors and Uncertainties in NCAR Aircraft Pyrgeometer Data," from MONEX. *American Meteorological Society Bulletin* 63:1387-1389.
- Ellingson, R. G.,** and G. N. Serafino. **1984.** "Observations and Calculations of Aerosol Heating Over the Arabian Sea During MONEX." *Journal of Atmospheric Sciences* 41:575-589.
- Eloranta, E. W.,** J. M. King, and J. A. Weinman. **1975.** "The Determination of Wind Speeds in the Boundary Layer by Monostatic Lidar." *Journal of Applied Meteorology* 14:1485-1489.
- Fiocco, G.,** and L. Smullin. **1989.** FIRE Phase II Research Plan. Available from FIRE Project Manager, NASA, Langley Research Center, Hampton VA 23665-5225.
- Fiocco, G.,** and L. D. Smullin. **1963.** *Nature* 199:1275.
- Fishman, J.,** V. Ramanathan, P. J. Crutzen, and S. C. Liu. **1979.** "Tropospheric Ozone and Climate." *Nature* 282:818-820.

- Fritschen, L. J., and L. W. Gay. 1979.** *Environmental Instrumentation*. Springer-Verlag, New York.
- Gates, L. W. 1985.** "Modeling as a Means of Studying the Climate System." Projecting the Climatic Effects of Increasing Carbon Dioxide. DOE/ER-0237. U.S. Department of Energy, Washington, DC.
- Gates, L. W. 1987.** "Problems and Prospects in Climate Modeling." In *Toward Understanding Climate Change*, ed. U. Radok, pp. 5-34. Westview Press, Boulder, Colorado.
- Ghan, S. J., J. E. Penner, and K. E. Taylor. 1989.** "Sulphate Aerosols and Climate." Scientific Correspondence. *Nature*340:438.
- Giorgi, F., and W. L. Chameides. 1986.** "Rainout Lifetimes of Highly Soluble Aerosols and Gases as Inferred From Simulations with a General Circulation Model." *Geophysical Research* 91:14367-14376.
- Grant, W. B. 1987.** "Laser Remote Sensing Techniques." In *Laser Spectroscopy and its Applications*, eds. L. J. Radziemski, et al., pp. 573-576. Marcel Dekker, Inc., New York.
- Grant, W. B. et al. 1987.** *Appl. Opt.* 3033.
- Grotch, S. L. 1988.** *Regional Intercomparisons of General Circulation Model Predictions and Historic Climate Data*. Technical Report DOE-NBB-0084, U.S. Department of Energy, Washington, DC.
- Gutowski, W. J., D. S. Gutzler, D. Portman, and W.-C. Wang. 1988.** *Surface Energy Balance of Three General Circulation Models: Current Climate and Response to Increasing Atmospheric CO₂*. Technical Report, DOE-ER-60422-H1, U.S. Department of Energy, Washington, DC.
- Hameed, S., and J. Dignon. 1988.** "Changes in the Geographical Distributions of Global Emissions of NO_x and SO_x From Fossil-Fuel Combustion Between 1967 and 1980." *Atmospheric Environment*22:441-449.
- Hansen, J. 1988.** "The Greenhouse Effect: Impacts on Current Global Temperature and Regional Heat Waves." Statement to United States House of Representatives Committee on Energy and Commerce, Subcommittee on Energy and Power, July 7.
- Hansen, J., A. Lacis, D. Rind, G. Russell, P. Stone, I. Fung, R. Ruedy, and J. Lerner. 1984.** "Climate Sensitivity: Analysis of Feedback Mechanisms." In *Climate Processes and Climate Sensitivity*, eds. J.E. Hansen and T. Takahashi, pp 368, Maurice Ewing Series, No. 5, American Geophysical Union, Washington, DC.
- Hansen, J., and S. Lebedeff. 1988.** "Global Surface Air Temperatures: Update Through 1987." *Journal of Geophysics Research* 15:323-326.
- Hansen, J., and S. Lebedeff. 1987.** "Global Trends of Measured Surface Air Temperature." *Journal of Geophysics Research* 92:13345-13372.
- Henderson-Sellers, A. 1989.** "North American Total Cloud Amount Variations This Century." *Global Planet Change* (In press.)
- Henderson-Sellers, A., and K. McGuffie. 1989.** "Scientific Correspondence: Sulphate Aerosols and Climate." *Nature*340:436-437.
- Hogg, D. C., M. T. Decker, F. O. Guiraud, K. B. Earnshaw, D. A. Merrit, K. P. Moran, W. B. Sweezy, R. G. Strauch, E. R. Westwater, and C. G. Little. 1983.** "An Automatic Profiler of the Temperature, Wind and Humidity in the Troposphere." *Journal of Climate Applied Meteorology*22:807-831.
- Holle, R. L., and S. A. Mackay. 1975.** "Tropical Cloudiness From All-Sky Cameras on Barbados and Adjacent Atlantic Ocean." *Journal of Applied Meteorology*14:1437-1450.

- Holligan, P. M.,** M. Vollier, D. S. Harbour, P. Camus, and M. Champagne-Phillipe. 1983. "Satellite and Ship Studies of Coccolithophore Production Along a Continental Shelf Edge." *Nature* 304:399-342.
- Ismail, S.,** and E. V. Browell. 1989. *Applied Optics* 28:3603.
- Jerlov, J. G.** 1976. *Marine Optics*. Elsevier.
- Jones, P. D.,** T.M.L. Wigley, C. K. Folland, and D. E. Parker. 1988. "Spatial Patterns in Recent Worldwide Temperature Trends." Climatic Research Unit, University of East Anglia, United Kingdom. *Climate Monitor* 16:175-185.
- Jones, P. D.,** S.C.B. Raper, R. S. Bradley, H. F. Diaz, P. M. Kelly, and T.M.L. Wigley. 1986b. "Northern Hemisphere Surface Air Temperature Variations: 1851-1984." *Journal of Climate Applied Meteorology* 25:161-174.
- Jones, P. D.,** S.C.B. Raper, and T.M.L. Wigley. 1986c. "Southern Hemisphere Surface Air Temperature Variations: 1851-1984." *Journal of Climate Applied Meteorology* 25:161-174.
- Jones, P. D.,** T.M.L. Wigley, and P. B. Wright. 1986a. "Global Temperature Variations Between 1861 and 1984." *Nature* 332:430-434.
- Jones, P. D.** 1988. "The Influence of ENSO on Global Temperatures." Climatic Research Unit, University of East Anglia, United Kingdom. *Climate Monitor* 17:80-89.
- Kanemasu, E. T.,** M. L. Wesely, B. B. Hicks, and J. L. Heilman. 1979. "Techniques for Calculating Energy and Mass Fluxes." In *Modification of the Aerial Environment of Crops*, eds. B. J. Barfield and J. F. Gerber, pp. 156-182. *American Society of Agricultural Engineers*, St. Joseph, Michigan.
- Kangas, K. W.,** et al. 1989. *Opt. Lett.* 14:21
- Kessler, E.** 1969. "The Distribution and Continuity of Water Substance in Atmospheric Circulation." *American Meteorological Society, Merorol. Monogr.* 10:32.
- Kirk, J.T.O.** 1983. *Light and Photosynthesis in Aquatic Ecosystems*. Cambridge University Press. New York.
- Kneizys, F.,** R. Gruenzel, W. Martin, M. Schuwerk, W. Gallery, S. Clough, J. Chetwynd, and E. Shettle. 1984. *Comparison of 8-12 and 3-5 micron CVF Transmissometer Data with LOWTRAN Calculations*. Report AFGL-TR-84-0171, Air Force Geophysics Laboratory, Hanscom AFB, Massachusetts.
- Kristenson, L.,** and J. Gaynor. 1986. "Errors in Second Moments Estimated From Monostatic Doppler Sodar Winds, Part I: Theoretical Description." *Journal of Atmospheric Oceanic Technology* 3:523-528.
- Kropfli, R. A.,** and P. H. Hildebrand. B. "Three-Dimensional Wind Measurements in the Optically Clear Planetary Boundary Layer with Dual-Doppler Radar." *Radio Sci.* 15:283-296.
- Kunde, V. G.** et al. 1987. "Infrared Spectroscopy of the Lower Stratosphere with a Balloon-borne Cryogenic Fourier Spectrometer." *Appl. Opt.* 92:545.
- Kuo, H. L.** 1974. "Further Studies of the Parameterization of the Influence of Cumulus Convection on Large-Scale Flow." *Journal of Atmospheric Sciences* 31:1232-1240.
- Lee, I. Y.** 1989. *Parameterizations of Microphysical Processes in Clouds*. Technical Report, Argonne National Laboratory (in preparation).
- Lee, I. Y.,** and M. S. Hong. 1987. *A Review of Parameterizations of Microphysical Processes in Clouds For Application in Models of Regional Atmospheric Deposition*. Technical Report, ANL-87-32. Argonne National Laboratory.
- Lin, Y.L.,** R.D. Farley, and H.D. Orville. 1983. "Bulk Parameterizations of Snow Fields in a Cloud Model." *Journal of Climate and Applied Meteorology* 22:1065-1092.
- Luther, F. A.,** R. G. Ellingson, Y. Fouquart, S. Fels, N. A. Scott, and W. J. Wiscombe. 1988. "Intercomparison of Radiation Codes in Climate Models (ICRCCM): Longwave Clear-Sky Results-A Workshop Summary." *American Meteorological Society Bulletin* 69:40-48.

- Luther, F., ed. 1984.** *The Intercomparison of Radiation Codes in Climate Models*, World Meteorological Organization, World Climate Program Report WCP-93, Geneva, Switzerland.
- Luther, F. M. 1983.** "Results of a Comparison of Infrared Radiative Transfer Models." Presented at the IAMAP General Assembly. August 15-17, 1983. Hamburg, FRG.
- Luther, F. M. 1982.** "Radiative Effects of a CO₂ Increase: Results of a Model Comparison." In *Proceedings of the Carbon Dioxide Research Conference: Carbon Dioxide, Science and Consensus*. DOE CONF-820970, pp. III.177-193. September 19-23, 1982. Berkeley Springs, West Virginia.
- Manabe, S., and R. T. Wetherald. 1987.** "Large Scale Changes of Soil Wetness Induced by and Increase in Atmospheric Carbon Dioxide." *J. Atmos. Sci.* 44:1211-1235.
- Marshall, J. M., A. M. Peterson, and A. A. Branes, Jr. 1972.** "Combined Radar-Acoustic Sounding System." *Appl. Opt.* 11:108-112.
- Matuura, N., Y. Masuda, H. Inuki, S. Kato, S. Fukao, T. Sato, and T. Tsuda. 1986.** "Tadai Acoustic Measurement of Temperature Profile in the Troposphere and Stratosphere." *Nature* 323:426-428.
- May, P., R. Strauch, and K. Moran. 1988.** "The Altitude Coverage of Temperature Measurements Using RASS with Wind Profiler Radars." *Geophys. Res. Lett.* 15:1381-1384.
- McArthur, L. B., and J. E. Hay. 1979.** "On the Anisotropy of Diffuse Solar Radiation." *American Meteorological Society Bulletin* 59:1442-1443.
- McClatchey, R. A., R. W. Fenn, J. E. A. Selby, F. E. Volz, and J. S. Garing. 1971.** "Optical Properties of the Atmosphere." AFCRL-71-0279, Air Force Cambridge Research Laboratories, Bedford, Massachusetts.
- McCormick, M. P. 1986.** "The Lidar In-Space Technology Experiment (LITE)." Thirteenth International Laser Radar Conference, Toronto, August 1986. NASA Conference Publication 2431 (Abstracts), National Aeronautics and Space Administration, ADDRESS.
- McGuffie, K., and A. Henderson-Sellers. 1989.** "Almost a Century of 'Imaging' Clouds Over the Whole-Sky Dome." *American Meteorological Society Bulletin* 70:1243-1253.
- Melfi, S., D. Whiteman, and R. Ferrarri. 1989.** "Observation of Atmospheric Fronts Using Raman Lidar Moisture Measurements." *J. Appl. Met.*
- Melfi, S. H. 1972.** *Appl. Opt.* 11:160.
- Melfi, S. H., and D. Whiteman. 1985.** "Observation of Lower-Atmospheric Moisture Structure and Its Evolution Using a Raman Lidar." *American Meteorological Society Bulletin* 66:1288.
- Melfi, S. H., et al. 1988.** In *Proceedings of Lower Tropospheric Profiling: Needs and Technologies*. Sponsored by NCAR, NOAA/WPL, and AMS, Boulder, Colorado.
- Michalsky, J. J., and B. A. LeBaron. 1989.** "Spectral and Temperature Correction of Silicon Photodiode Solar Radiation Detectors." In *Proceedings of the 1989 American Solar Energy Society Meetings*, ed. M. J. Coleman. Denver, Colorado.
- Miller, D. H. 1981.** *Energy at the Surface of the Earth*. Academic Press, New York.
- Muller, C. H. et al. 1988.** *Opt. Lett.* 13:380.
- Murcray, D. G. 1984.** "Atmospheric Transmission in the 750-200 cm⁻¹ Region." *J. Quant. Spect. Rad. Trans.* 32:381-396.

Murcay, F. H., F. J. Murcay, D. G. Murcay, J. Pritchard, G. Vanasse, and H. Sakai. **1984**. "Liquid Nitrogen-cooled Fourier Spectrometer System for Measuring Atmospheric Emission at High Altitudes." *J. Atmos. Ocean. Tech.* 1:351-357.

National Center for Atmospheric Research. **1989**. Preliminary Draft, STORM I, The First Central U.S. Multiscale Experiment—Experiment Design, September 1, 1989. 163 pp. STORM Project Office, National Center for Atmospheric Research, P.O. Box 3000, Boulder, Colorado 80307.

National Research Council. **1986**. "U.S. Participation in the TOGA Program: A Research Strategy." Advisory Panel for TOGA, National Research Council. National Academy Press, Washington, D.C.

Ogura, Y., and T. Takahashi. **1971**. "Numerical Simulation of the Life Cycle of a Thunderstorm Cell." *Monthly Weather Review* 99:895-911.

Potter, G. L., and R. D. Cess. **1984**. "Background Tropospheric Aerosols: Incorporation Within a Statistical-Dynamical Climate Model." *Journal of Geophysics Research* 89:9521-9526.

Pueschel, R. F., C. C. Van Valin, R. G. Castillo, J. A. Kadlecek, and E. Ganor. **1986**. "Aerosols in Polluted Versus Nonpolluted Air Masses: Long-Range Transport and Effects on Clouds." *Journal of Climate and Applied Meteorology* 25:1908-1917.

Radke, L. F., and P. V. Hobbs. **1976**. "Cloud Condensation Nuclei on the Atlantic Seaboard of the United States." *Science* 193:999-1002.

Radke, L. F. **1989**. "Airborne Observations of Cloud Microphysics Modified by Anthropogenic Forcing." In *Proceedings of the American Meteorological Society Symposium on the Role of Clouds in Atmospheric Chemistry and Global Climate*, pp. 310-315, January 30 - February 3, 1989, Anaheim, California.

Ramanathan, V. **1988**. *Science* 240:293.

Ramanathan, V. **1988**. "The Greenhouse Theory of Climate Change: A Test by an Inadvertent Global Experiment." *Science* 240:293-299.

Ramanathan, V., R. D. Cess, E. F. Harrison, P. Minnis, B. R. Barkstrom, E. Ahmad, and D. Hartmann. **1989**. "Cloud-Radiative Forcing and Climate: Results From the Earth Radiation Budget Experiment." *Science* 243:57-63.

Rao, C. R., Stowe, L. L. and McClain, E. P. **1988**. "Development and application of aerosol remote sensing with AVHRR data from the NOAA satellites." In *Aerosols and Climate*, eds. P.V. Hobbs and M.P. McCormick, pp. 69-79.

Reuter, D., J. Susskind, and A. Pursch. **1988**. "First-Guess Dependence of a Physically Based Set of Temperature-Humidity Retrievals From HIRS2/MSU Data." *Journal of Atmospheric Oceanic Technology* Vol:70-83.

Revercomb, H. E., H. Buijs, H. B. Howell, D. D. LaPorte, W. L. Smith, and L. A. Sromovsky. **1988**. "Radiometric Calibration of IR Fourier Transform Spectrometers: Solution to a Problem with the High-resolution Interferometer Sounder." *Appl. Opt.* 27:3210-3218.

Riordan C., D. Myers, M. Rymes, R. Hulstrum, W. Marion, C. Jennings, and C. Whitaker. **1989**. "Spectral Solar Radiation Data Base at SERI." *Solar Energy* 42:67-79.

Roberts, R., J. Selby and L. Biberman. B. "Infrared Continuum Absorption by Atmospheric Water Vapor in the 8-12 micron Window." *Appl. Opt.* 15:2085.

Rodgers, C. D., and C. D. Walshaw. **1966**. "The Computation of Infrared Cooling Rates in Planetary Atmospheres." *Quarterly Journal Roy. Meteorological Society* 92:67-92.

Rosenberg, N. J., B. L. Blad, and S. B. Verma. **1983**. *Microclimate, The Biological Environment*. John Wiley & Sons, Inc., New York.

- Ryaboshapko, A. G. 1983.** "The Atmospheric Sulphur Cycle in The Global Biogeochemical Sulphur Cycle," eds. M. V. Ivanov and J. R. Freney, pp. 203-296. SCOPE Report 19, John Wiley & Sons, New York.
- Savoia, D. L., and J. M. Prospero. 1989.** "Comparison of Oceanic and Continental Sources of Non-Sea Salt Sulphate Over the Pacific Ocean." *Nature* 339:685-687.
- Schlesinger, M. 1984.** "Climate Model Simulations of CO₂-Induced Climate Change." In *Advances in Geophysics*, ed. B. Saltzman, Vol 26, pp. 141-235. Academic Press, New York.
- Schlesinger, M. E., and J.F.B. Mitchell. 1987.** "Climate Model Simulations of the Equilibrium Climate Response to Increased Carbon Dioxide." *Rev. Geophys.* 25:760-798.
- Schlesinger, M. E., and J. B. Mitchell. 1985.** "Model Projections of the Equilibrium Climate Response to Increased Carbon Dioxide." In *Projecting the Climatic Effects of Increasing Carbon Dioxide*, eds. M. C. MacCracken and F. M. Luther, DOE-ER-0235, U.S. Department of Energy, Washington, D.C.
- Schneider, S.H. 1989.** "The Greenhouse Effect: Science and Policy." *Science* 243:771-781.
- Schwartz, S. E. 1989.** "Control of Global Cloud Albedo and Climate by Marine Dimethylsulfide Emissions: A Test by Anthropogenic Sulfur Dioxide Emissions." In *Proceedings of the American Meteorological Society Symposium on the Role of Clouds in Atmospheric Chemistry and Global Climate*, pp. 4-8, January 30 - February 3, 1989, Anaheim, California.
- Schwartz, S. E. 1989.** *Science* 243:753-763.
- Schwartz, S. E. 1988.** "Are Global Cloud Albedo and Climate Controlled by Marine Phytoplankton?" *Nature* 336:441-445.
- Schwiesow, R. L., and L. Lading. 1981.** "Temperature Profiling by Rayleigh Scattering Lidar." *Applied Optics* 20:1972-1979.
- Schwiesow, R. L. 1983.** "Potential for a Lidar-Based, Portable, 1 km Meteorological Tower." *Journal Climate Applied Meteorology* 22:881-890.
- Seitz, F., R. Jastrow, and W. A. Nierenberg. 1989.** "Scientific Perspectives on the Greenhouse Problem." George C. Marshall Institute, Washington, D.C.
- Sellers, P. J., F. G. Hall, G. Asrar, D. E. Strebel, and R. E. Murphy. 1988.** "The First ISLSCP Field Experiment (FIFE)." *Bulletin of the American Meteorological Society* 69:22-27.
- Slingo, T. 1988.** "Can Plankton Control Climate?" *Nature* 336:421.
- South Dakota School of Mines and Technology. 1989.** Hailswath II, Preliminary Experiment Design 1989. 104 pp. South Dakota School of Mines and Technology, 501 East St. Joseph Street, Rapid City, South Dakota 57701.
- Sroga, J. T., and E. W. Eloranta. 1980.** "Lidar Measurement of Wind Velocity Profiles in the Boundary Layer." *Journal of Applied Meteorology* 19:598-605.
- Stokes, G. M., J. C. Barnard, and E. W. Pearson. 1984.** *Historical Carbon Dioxide Abundances Derived from the Smithsonian Spectrograms*. DOE-NBB-0063, U.S. Department of Energy, Washington, DC.
- Ten Brink, H. M., S. E. Schwartz, and P. H. Daum. 1987.** "Efficient Scavenging of Aerosol Sulfate by Liquid-Water Clouds." *Atmospheric Environment* 21:2035-2052.
- Tripoli, G. J., and W. R. Cotton. 1988b.** "A Numerical Study of an Observed Orographic Mesoscale System. Part 2: An Analysis of Governing Dynamics." *Monthly Weather Review*.
- Tripoli, G. J., and W. R. Cotton. 1988a.** "A Numerical Study of an Observed Orographic Mesoscale System. Part 1: Simulated Genesis and Comparison with Observations." *Monthly Weather Review*.

- Twomey, S. 1977.** Atmospheric Aerosols. pp. 278-290, Elsevier, New York.
- Twomey, S., M. Piepgrass, and T. L. Wolfe. 1984.** "An Assessment of the Impact of Pollution on Global Cloud Albedo." *Tellus* 36B:356-366.
- U.S. Department of Energy. 1986.** *Projecting the Climatic Effects of Increasing Carbon Dioxide*. State of the Art Report, Washington, DC.
- U.S. Department of Energy. 1986.** *Direct Effects of Increasing Carbon Dioxide on Vegetation*. State of the Art Report, Washington, DC.
- U.S. Department of Energy. 1986.** *Detecting the Climatic Effects of Increasing Carbon Dioxide*. State of the Art Report, Washington, DC.
- U.S. Department of Energy. 1986.** *Atmospheric Carbon Dioxide and the Global Carbon Cycle*. State of the Art Report, Washington, DC.
- Varanasi, P. 1988.** "Infrared Absorption by Water Vapor in the Atmospheric Window." *Modeling of the Atmosphere*, SPIE, 928:213-230.
- Wang, W. C., et al. 1988.** *Surface Energy Balance of Three General Circulation Models: Current Climate and Response to Increasing Atmospheric CO₂*. Technical Report DOE/ER/60422-H1, U.S. Department of Energy, Washington, DC.
- Washington, W. M., and G. A. Meehl. 1984.** "Seasonal Cycle Experiments on the Climate Sensitivity Due to a Doubling of CO₂ with an Atmospheric General Circulation Model Coupled to a Simple Mixed Layer Ocean Model." *J. Geophys. Res.* 89:9475-9503.
- Westwater, E. R., W. Zhenhui, N. Grody, and L. McMillin. 1985.** "Remote Sensing of Temperature Profiles from a Combination of Observations from the Satellite-Based Microwave Sounding Unit and the Ground-based Profiler." *Journal of Atmospheric Oceanic Technology* 2:97-110.
- Wigley, T.M.L. 1989.** "Possible Climate Change Due to SO₂ Derived Cloud Condensation Nuclei." *Nature* 339:365-367.
- Wigley, T.M.L., and S.C.B. Raper. 1987.** "Thermal Expansion of Sea Water Associated with Global Warming." *Nature* 330:127-131.
- Wilkerson, T. D., and G. K. Schwemmer. 1986.** In *Proceedings of Lower Tropospheric Profiling: Needs and Technologies*. Sponsored by NCAR, NOAA/WPL, and AMS, Boulder, Colorado.
- World Meteorological Organization. 1988.** *Concept of the Global Energy and Water Cycle Experiment*. World Climate Research Programme Report WCRP-5, WMO/TD-No. 215. Available from WMO, Geneva.
- World Meteorological Organization. 1984.** "The Intercomparison of Radiation Codes in Climate Models (ICRCCM), Longwave Clear-Sky Calculations." Report of a meeting in Frascati, Italy, August 15-18. World Climate Programme Report WCP - 93. Available from WMO, Geneva, Switzerland.
- World Meteorological Organization. 1983.** Informal Report of Expert Meeting to Plan an Intercomparison Programme for Radiation Codes Used in Climate Models. Meteorologie Nationale, Paris, France. June 20-23. Report available from WMO, Geneva, Switzerland.

Acronyms and Abbreviations

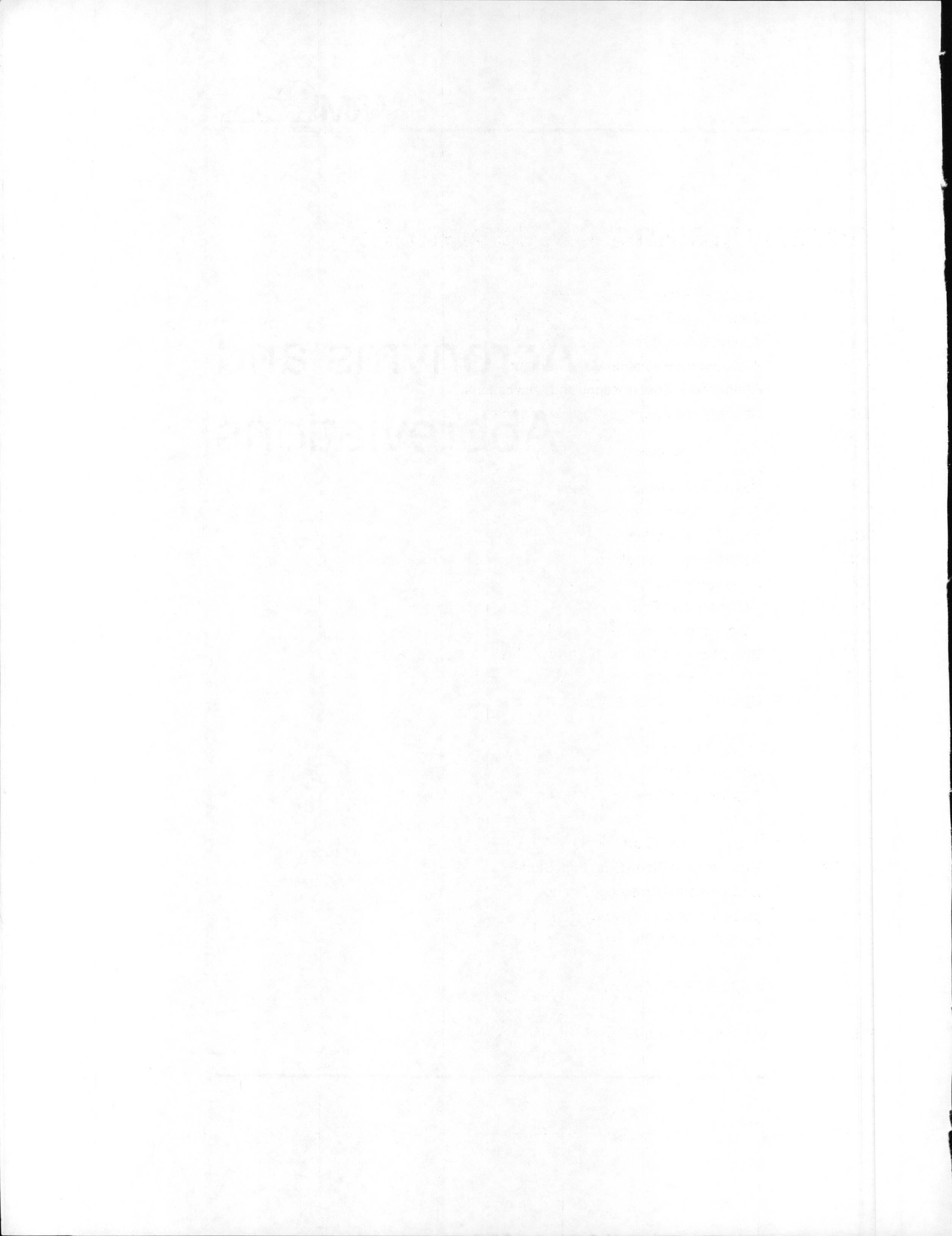

Acronyms and Abbreviations

| | |
|--------|---|
| AAAS | American Association for the Advancement of Science |
| ABLE | Atmospheric Boundary Layer Experiment |
| AFGL | Air Force Geophysics Laboratory |
| ARM | Atmospheric Radiation Measurement |
| ASA | Atmospheric Spectroscopy and Applications |
| ASCOT | Atmospheric Studies in Complex Terrain |
| BAO | Boulder Atmospheric Observatory |
| CART | Cloud and Radiation Testbed |
| CAS | Commission on Atmospheric Sciences |
| CCD | charge coupled devices |
| CCM | Community Climate Model |
| CCN | cloud condensation nuclei |
| CDF | Common Data Format |
| CDRD | Carbon Dioxide Research Division |
| CLARET | Cloud Lidar and Radar Exploratory Test |
| CLIC | Climate Inventory and Catalog |
| CZCS | Coastal Zone Color Scanner |
| DIAL | differential absorption lidar |
| DMS | dimethylsulfide |
| DOE | Department of Energy |
| EBBR | energy-balance Bowen ratio |
| ECLIPS | Experimental Cloud Lidar Pilot Study |
| EPA | Environmental Protection Agency |
| ER-2 | extended range U-2 (aircraft) |
| ERBE | Earth Radiation Budget Experiment |
| FIFE | First ISCCP Field Experiment |
| FIRE | First ISCCP Regional Experiment |
| FTS | Fourier Transform Spectrometer |

| | |
|----------|---|
| GBSRN | Global Baseline Surface Radiation Network |
| GCM | General Circulation Model |
| GEWEX | Global Energetics and Water Experiment |
| GFDL | Geophysical Fluid Dynamics Laboratory (NOAA) |
| GISS | Goddard Institute for Space Studies (NASA) |
| GSRN | Global Surface Radiation Network |
| | |
| HCN | Historical Climate Network |
| HIS | High-resolution Interferometer Sounder |
| | |
| ICRCCM | Intercomparison of Radiation Codes in Climate Models |
| IGAP | International Global Aerosol Program |
| IRC | International Radiation Commission |
| ISCCP | International Satellite Cloud Climatology Project |
| ISLSCP | International Satellite Land Surface Climatology Project |
| ITRA | Intercomparison of Transmittance Algorithms |
| | |
| JSC | Joint Scientific Committee |
| | |
| LANL | Los Alamos National Laboratory |
| LASE | Lidar Atmospheric Sensing Experiment |
| lidar | light detection and ranging |
| LTER | Long Term Ecological Research Program |
| | |
| MAP3S | Multistate Atmospheric Power Production Pollution Study |
| MCS | mesoscale convective systems |
| | |
| NADP/NTN | National Atmospheric Deposition Program/National Trends Network |
| NAPAP | National Acid Precipitation Assessment Program |
| NASA | National Aeronautics Space Administration |
| NBS | National Bureau of Standards |
| NCAR | National Center for Atmospheric Research |
| NCDC | National Climatic Data Center (NOAA) |
| NCDS | National Climate Data System (NASA) |

| | |
|-------|---|
| NEP | noise equivalent power |
| NH | Northern Hemisphere |
| NOAA | National Oceanic and Atmospheric Administration |
| NSF | National Science Foundation |
| NSSDC | National Space Science Data Center |
| OAST | Office of Aeronautics and Space Technology (NASA) |
| OER | Office of Energy Research |
| OSU | Oregon State University |
| PIR | Precision Infrared Radiometer |
| PNL | Pacific Northwest Laboratory |
| RASS | Radio Acoustic Sounding System |
| RDAAC | Remote Data, Analysis and Archive Center |
| RSR | Rotating Shadowband Radiometer |
| RSS | Rotating Shadowband Spectrometer |
| SDSD | Satellite Data Services Division |
| SH | Southern Hemisphere |
| SIFE | Second ISCCP Field Experiment |
| SOA | State-of-the-Art |
| SRB | surface radiation budget |
| SWADE | surface wave dynamic experiment |
| TOGA | Tropical Ocean - Global Atmosphere |
| UHF | ultra high frequency |
| USGS | United States Geological Service |
| VAD | Velocity Azimuth Display |
| VHF | very high frequency |

ARM Program Plan

| | |
|------|--|
| WCRP | World Climate Research Program |
| WGNE | Working Group on Numerical Experimentation |
| WGRF | Working Group on Radiative Fluxes |
| WMO | World Meteorological Organization |
| WOCE | World Ocean Circulation Experiment |
| WPL | Wave Propagation Laboratory |
| WRR | World Radiation Reference |



**UNITED STATES
DEPARTMENT OF ENERGY
ER-76 GTN
WASHINGTON, DC 20545**

Official Business
Penalty for Private Use, \$300



